

GROUND PLAN  
SCALE: 1/2" = 1'-0"

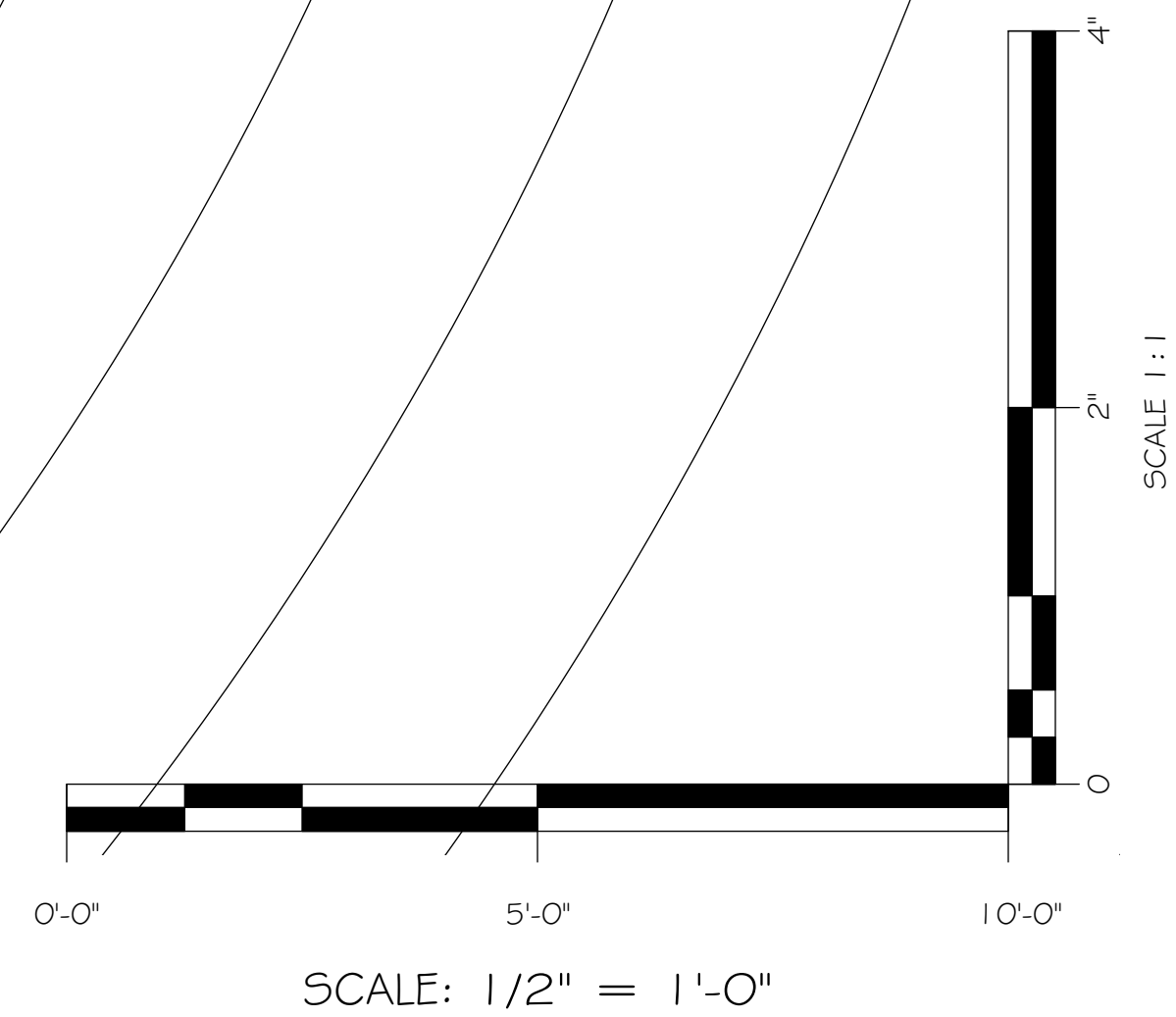

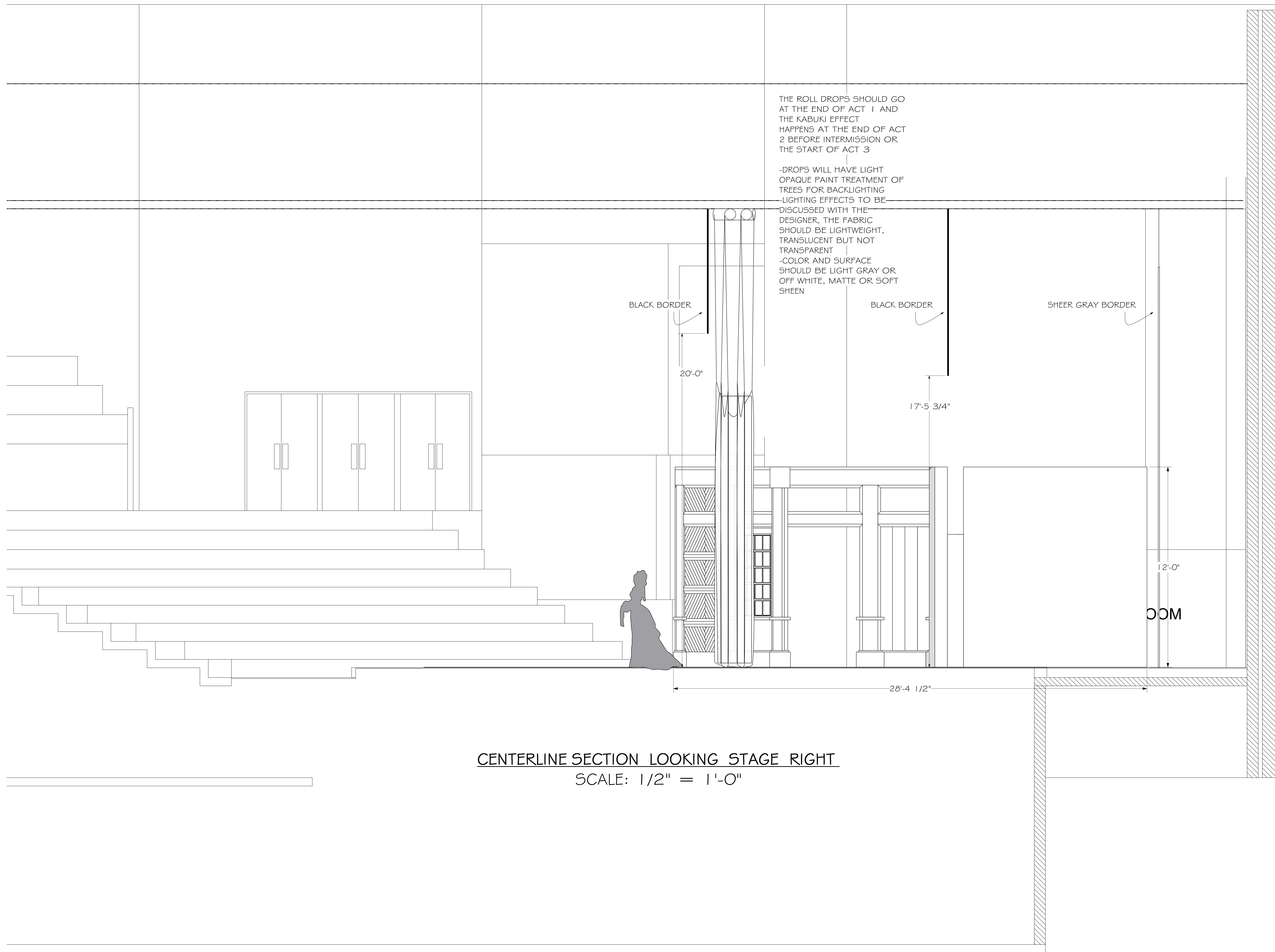

CENTERLINE SECTION LOOKING STAGE RIGHT  
SCALE: 1/2" = 1'-0"

SCALE 1/2" = 1'-0"

DRAWN ON 04.28.2020

CENTERLINE SECTION

MARX THEATRE

DESIGNED BY

CARI NOEL

PROFESSOR

JOE TILFORD

THE CHERRY ORCHARD

PAGE

2

8

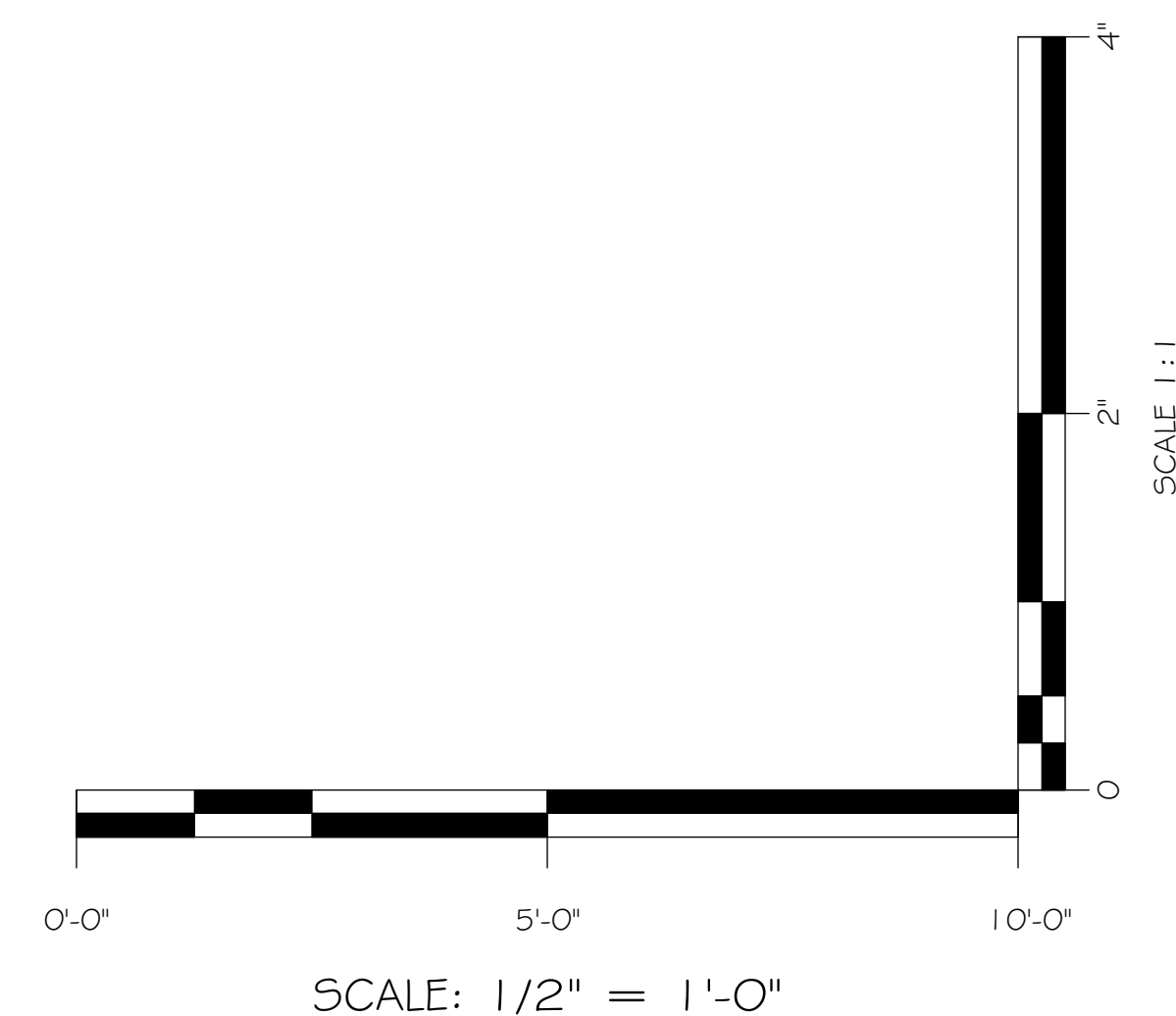

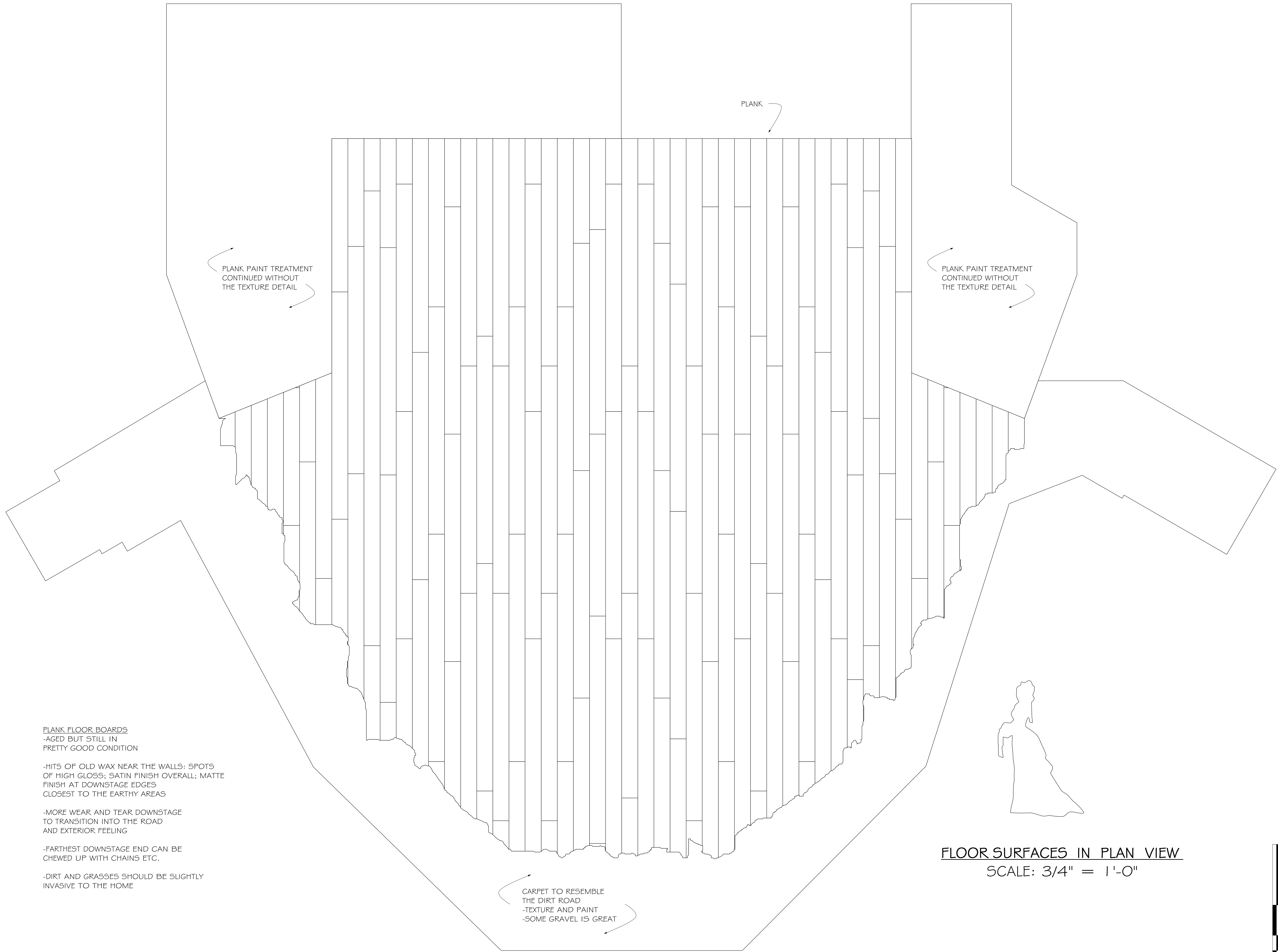

**PLANK FLOOR BOARDS**  
 -AGED BUT STILL IN  
 PRETTY GOOD CONDITION

-HITS OF OLD WAX NEAR THE WALLS; SPOTS  
 OF HIGH GLOSS; SATIN FINISH OVERALL; MATTE  
 FINISH AT DOWNSTAGE EDGES  
 CLOSEST TO THE EARTHY AREAS

-MORE WEAR AND TEAR DOWNSTAGE  
 TO TRANSITION INTO THE ROAD  
 AND EXTERIOR FEELING

-FARTHEST DOWNSTAGE END CAN BE  
 CHEWED UP WITH CHAINS ETC.

-DIRT AND GRASSES SHOULD BE SLIGHTLY  
 INVASIVE TO THE HOME

CARPET TO RESEMBLE  
 THE DIRT ROAD  
 -TEXTURE AND PAINT  
 -SOME GRAVEL IS GREAT

**FLOOR SURFACES IN PLAN VIEW**  
 SCALE: 3/4" = 1'-0"

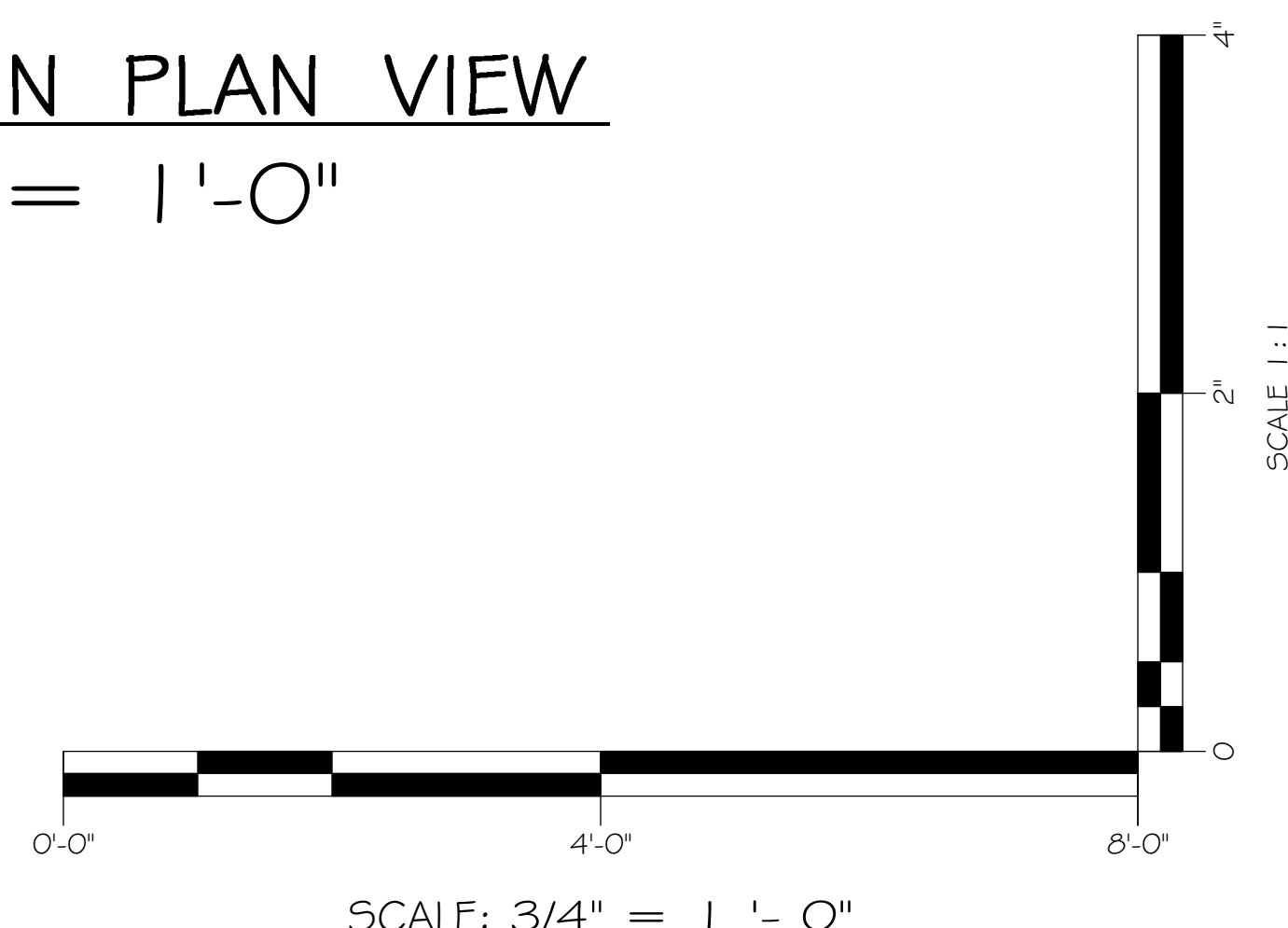

SCALE 3/4" = 1'-0"

DRAWN ON 04.28.2020

DECK

MARX THEATRE

DESIGNED BY

CARI NOEL

PROFESSOR

JOE TILFORD

THE CHERRY ORCHARD

PAGE

3

08

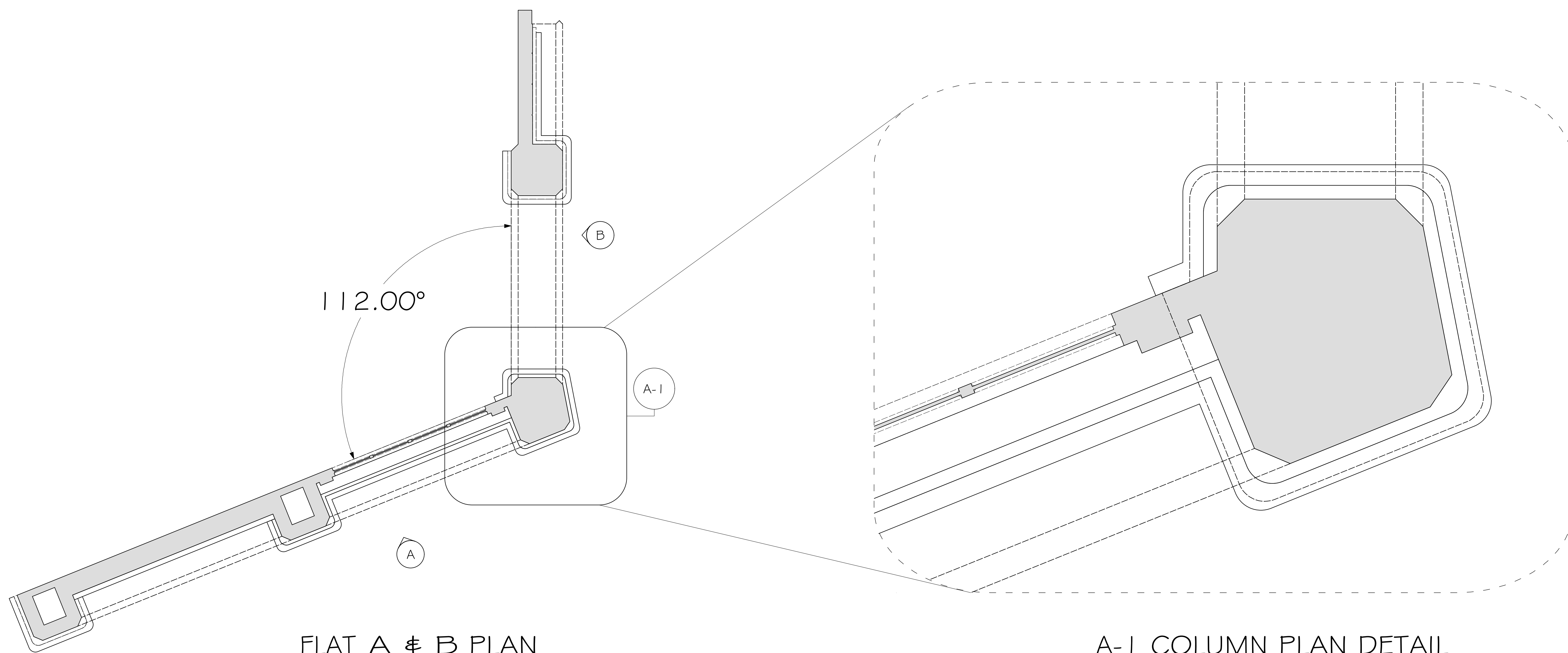

FLAT A & B PLAN  
SCALE: 3/4" = 1' - 0"

A-1 COLUMN PLAN DETAIL  
SCALE: 3" = 1' - 0"

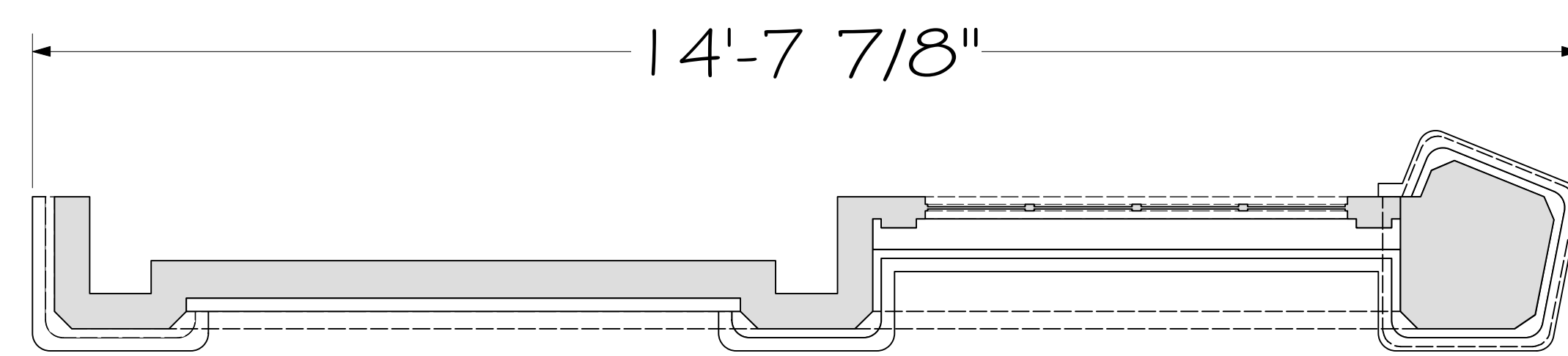

A FLAT A PLAN  
SCALE: 3/4" = 1' - 0"

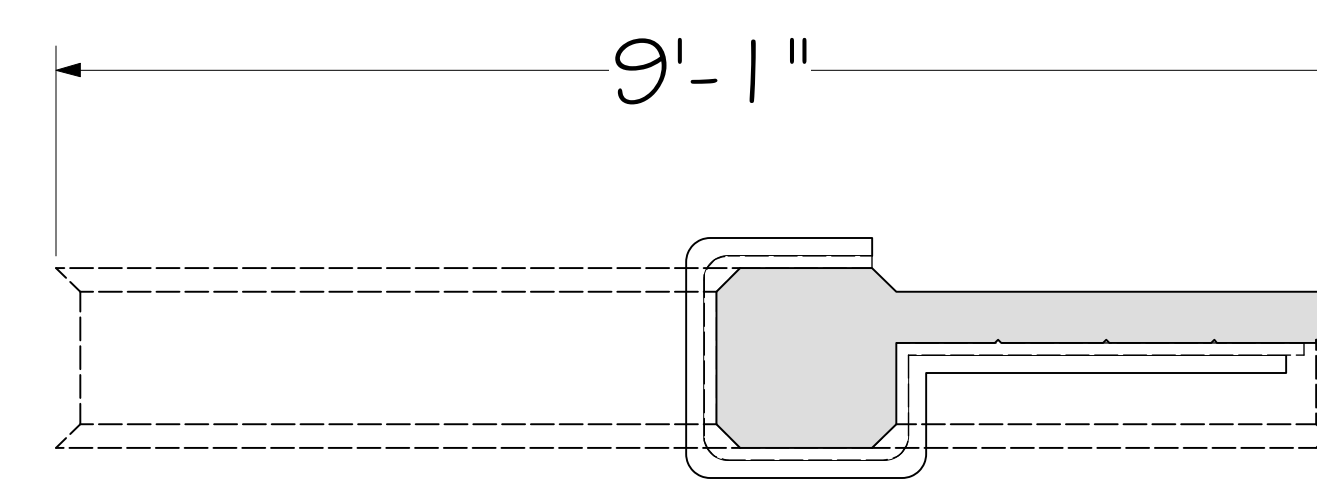

B FLAT B PLAN  
SCALE: 3/4" = 1' - 0"

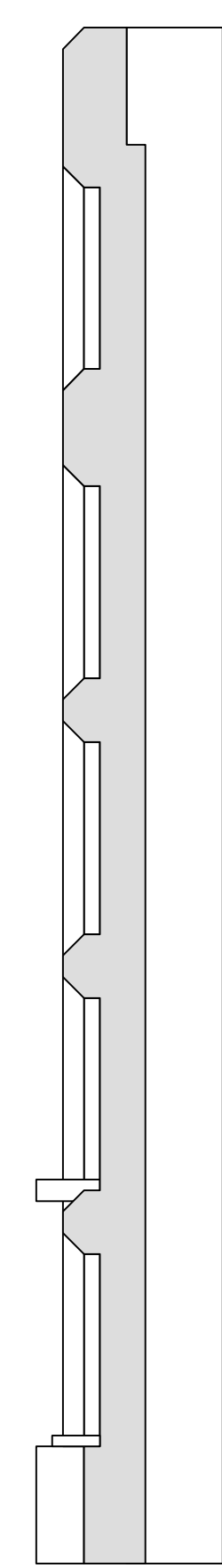

B-B SECTION  
FLAT A

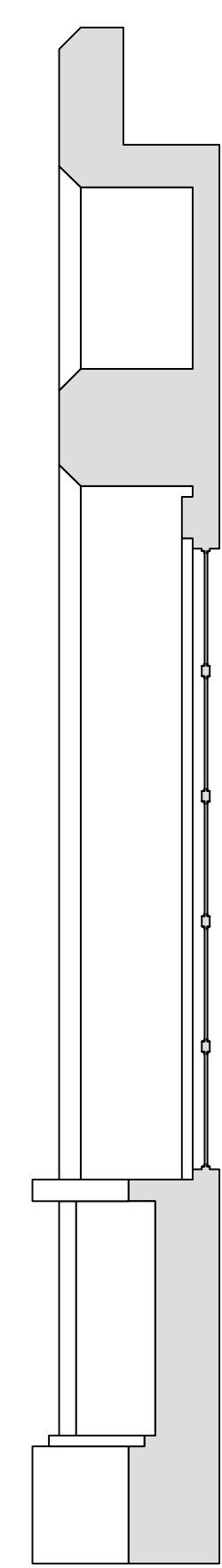

A-A SECTION  
FLAT A

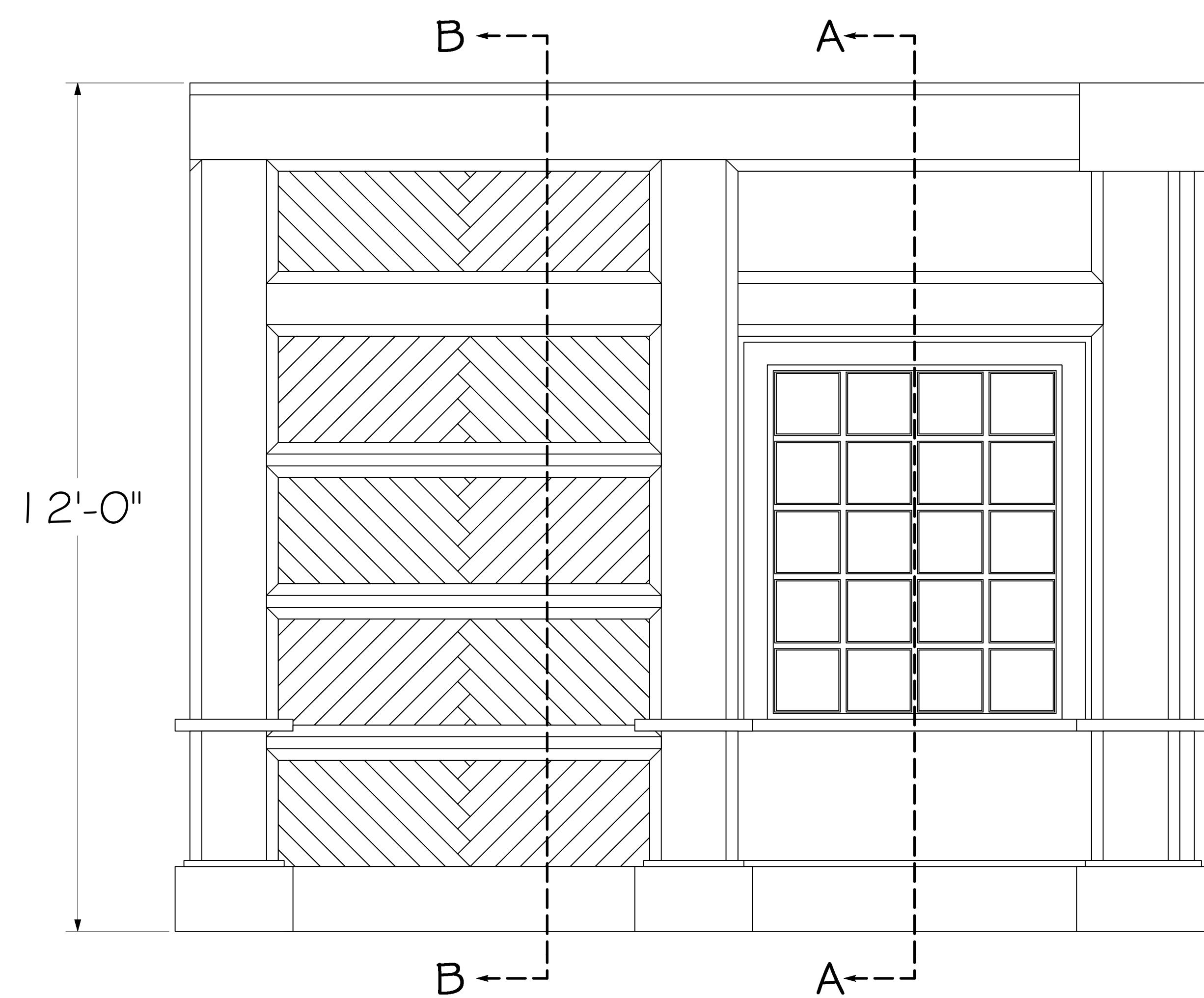

A FLAT A ELEVATION  
SCALE: 3/4" = 1' - 0"

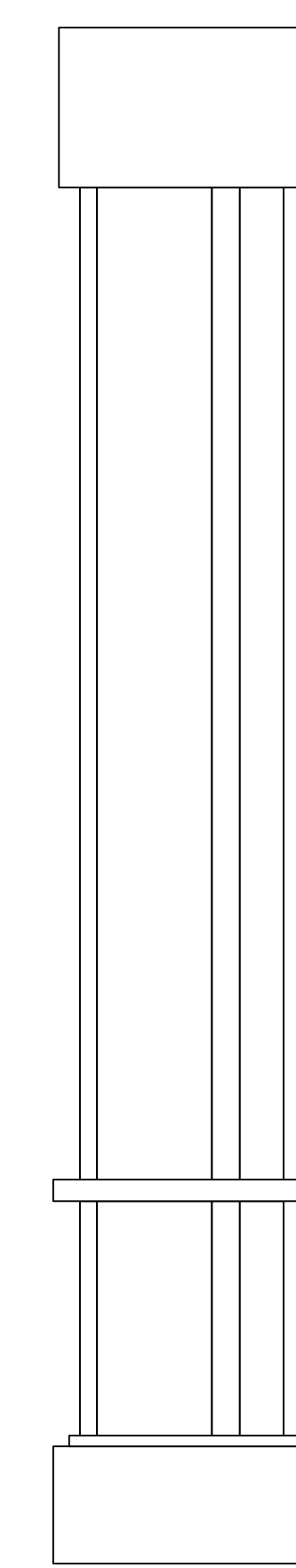

FLAT A COLUMN  
SIDE VIEW

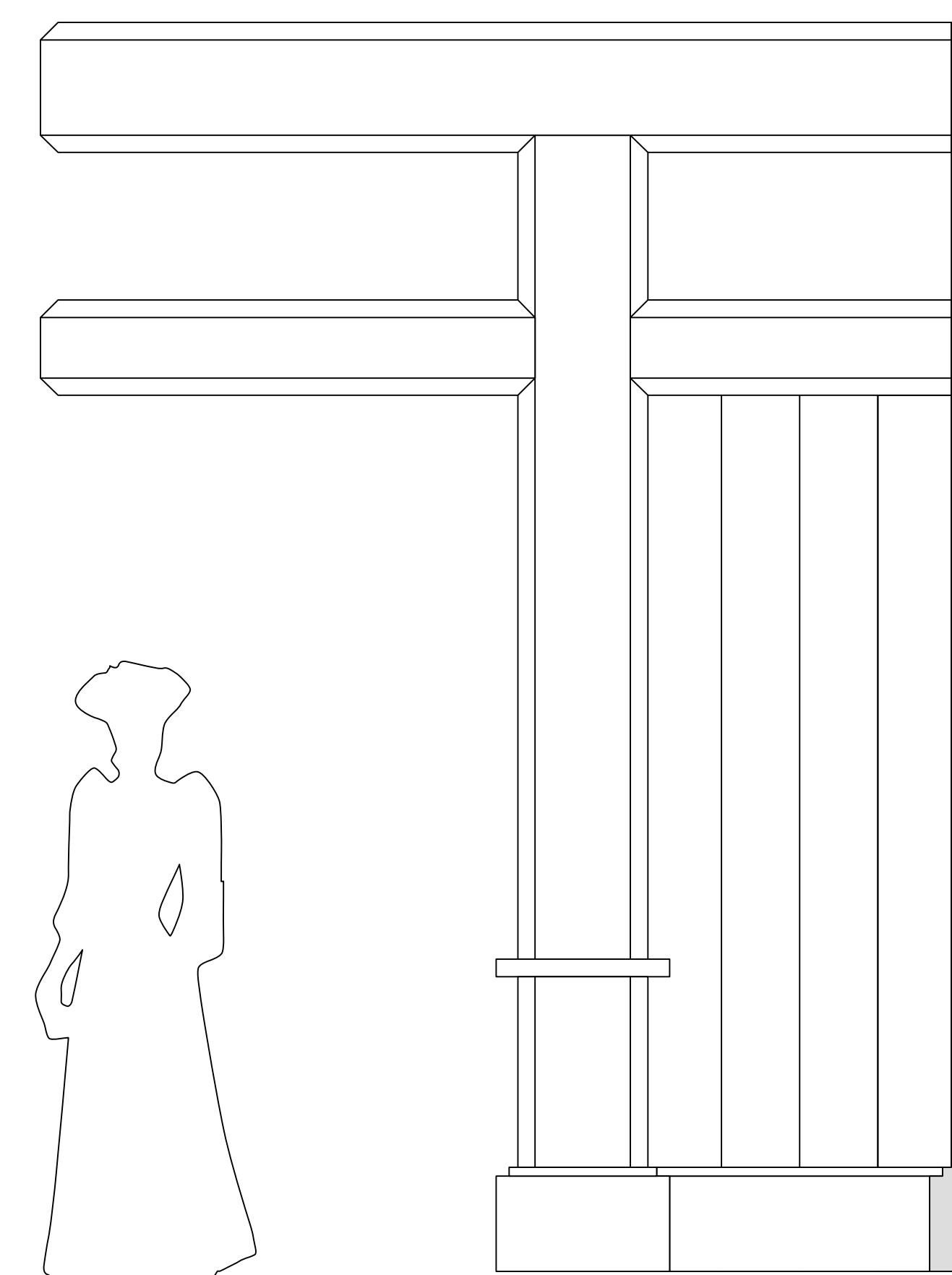

B FLAT B ELEVATION  
SCALE: 3/4" = 1' - 0"

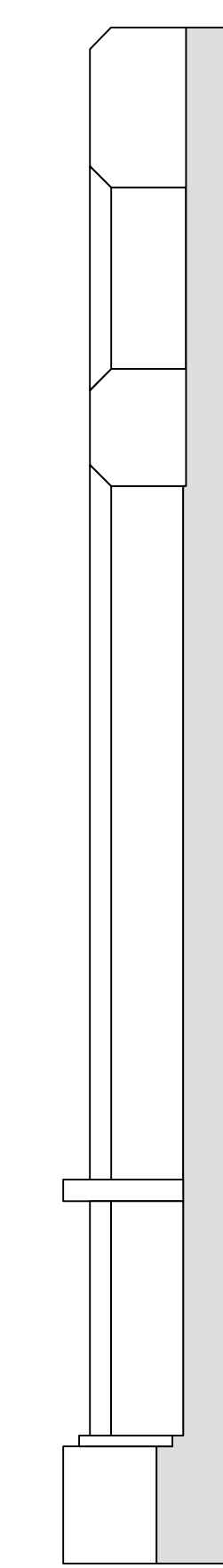

FLAT B  
SIDE VIEW

NOTE: FLATS A & B ON STAGE RIGHT ARE REVERSE AND REPEAT FOR D & E STAGE LEFT

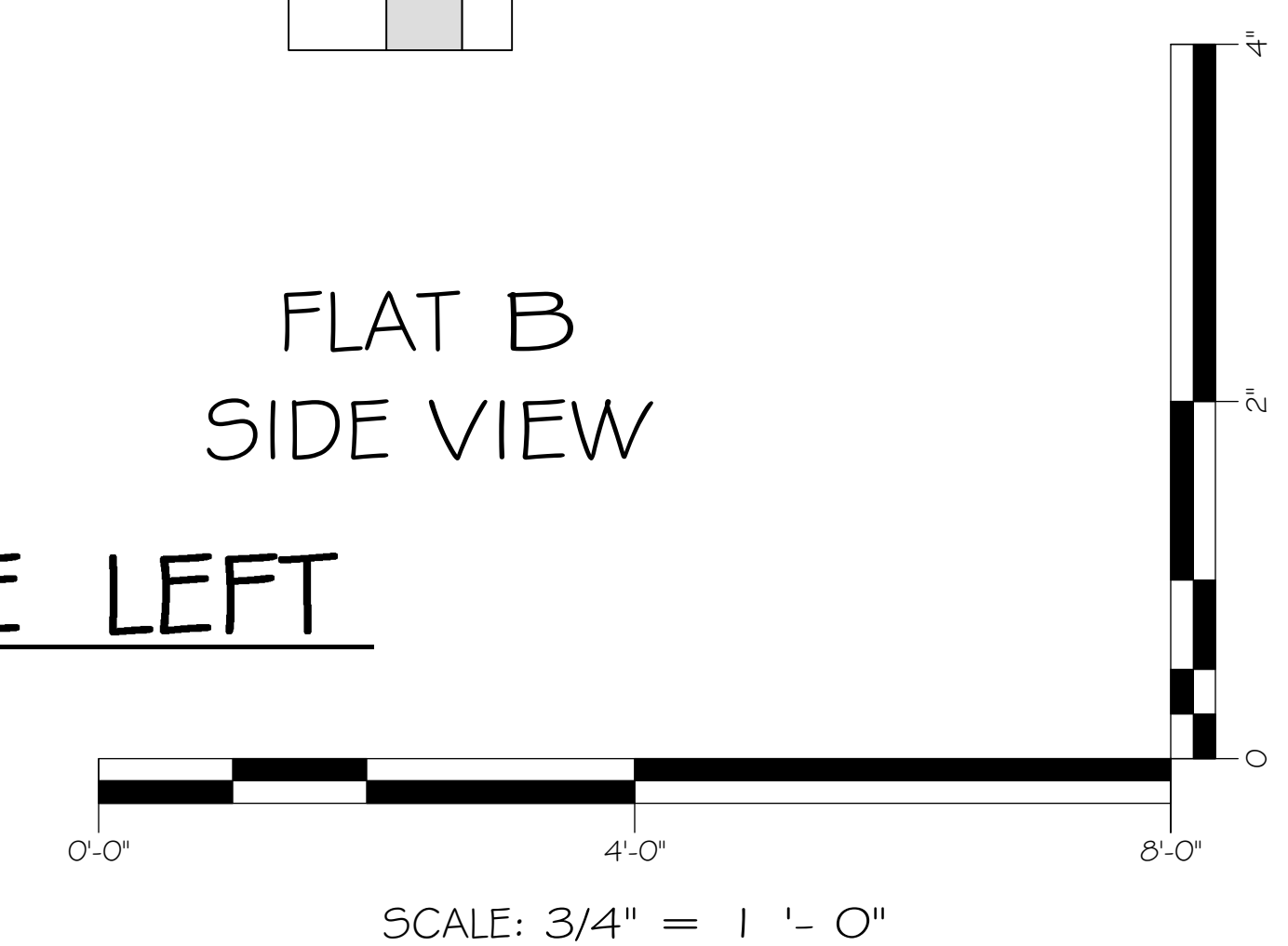

3/4" = 1' - 0"  
UNLESS OTHERWISE  
NOTED

FLAT A, B, D, & E ELEVATIONS	SCALE: 3/4" = 1' - 0"
MARX THEATRE	DRAWN ON 04.28.2020
DESIGNED BY CARI NOEL	PROFESSOR
	JOE TILFORD

THE CHERRY ORCHARD

PAGE

4

08

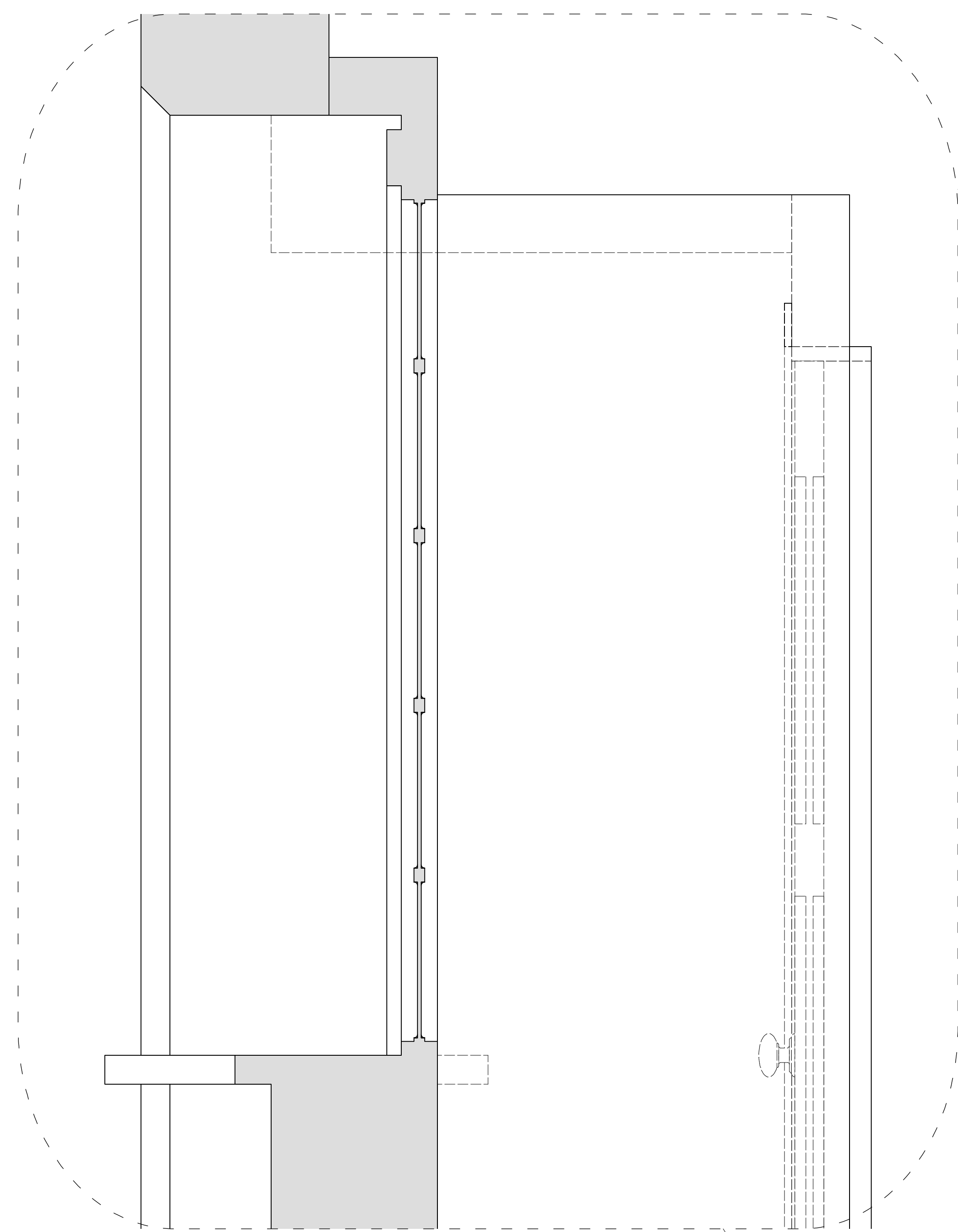

C-C SECTION DETAIL  
TYPICAL WINDOW  
SCALE 1 1/2" = 1' - 0"

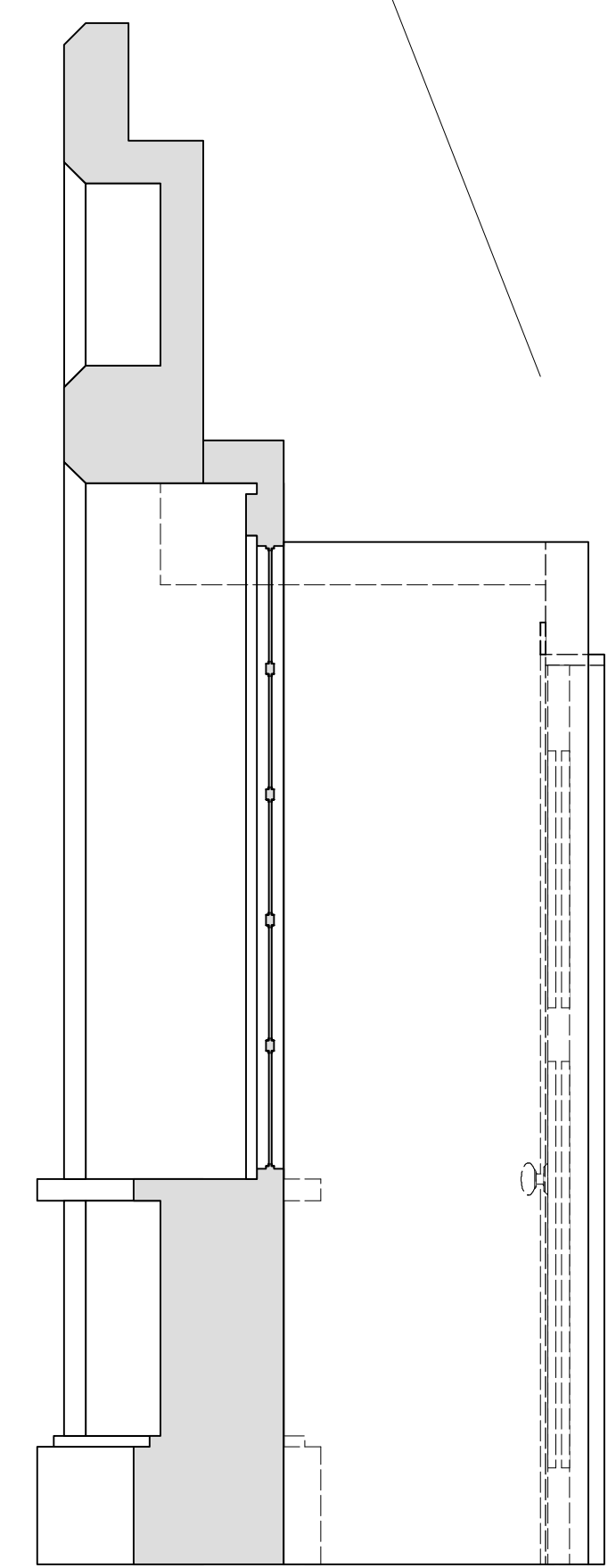

C-C SECTION  
FLAT C

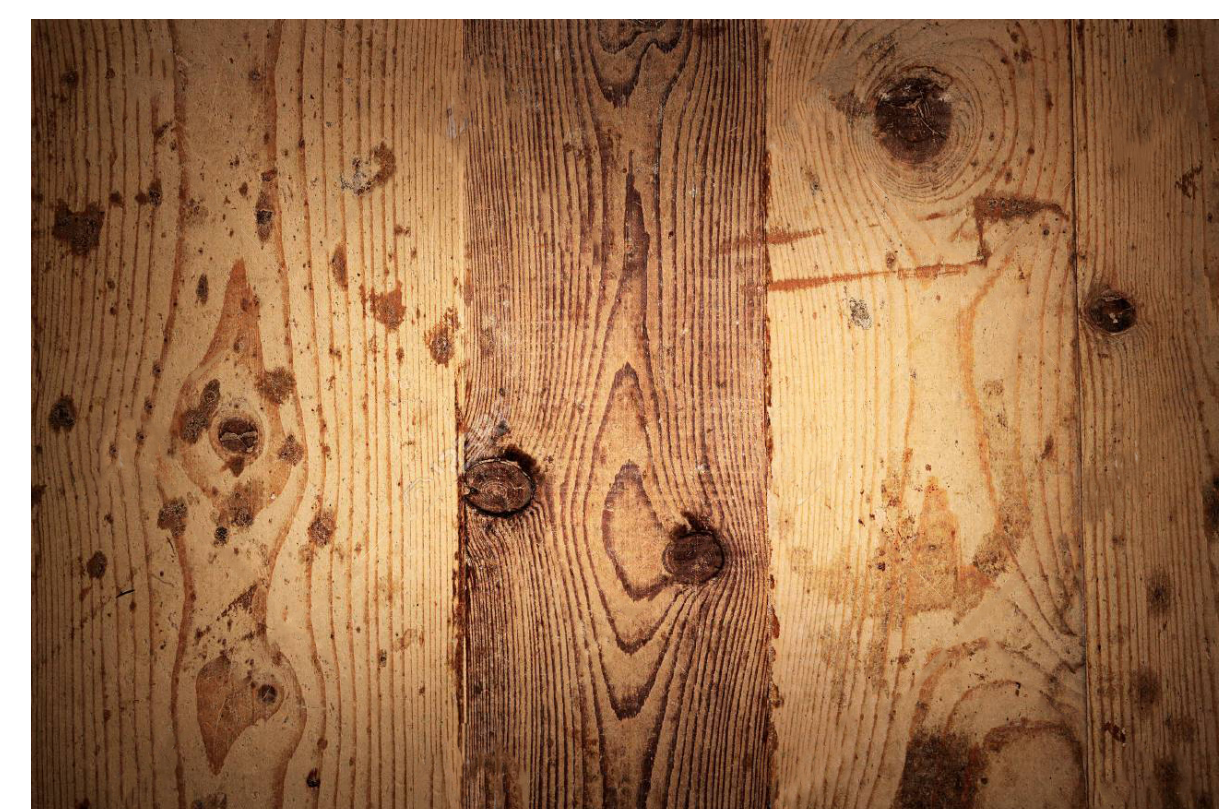
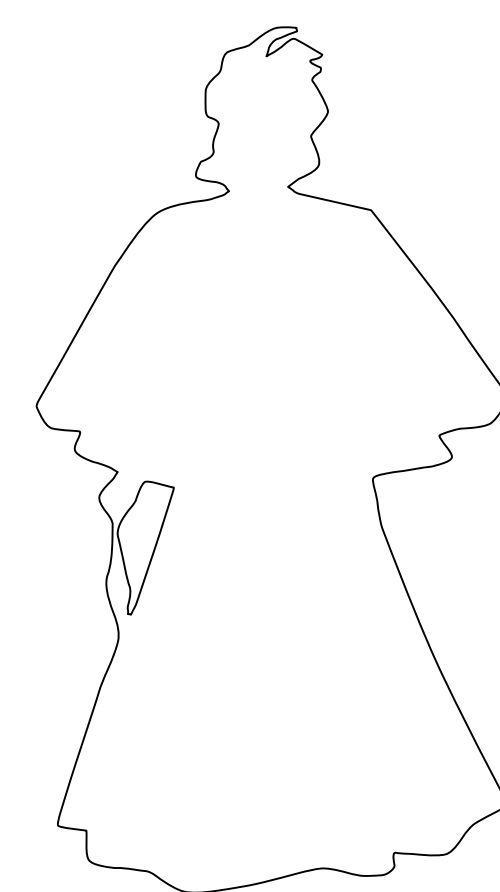

knob-and-escutcheon set by P. & F. Corbin appeared in the company's 1874-75 catalog, and also was produced in extremely rare cast enamel.

-Allen Joslyn  
source: <https://www.oldhouseonline.com/interiors-and-decor/unlocking-victorian-door-hardware>

DOOR HARDWARE  
SCALE: 1:1

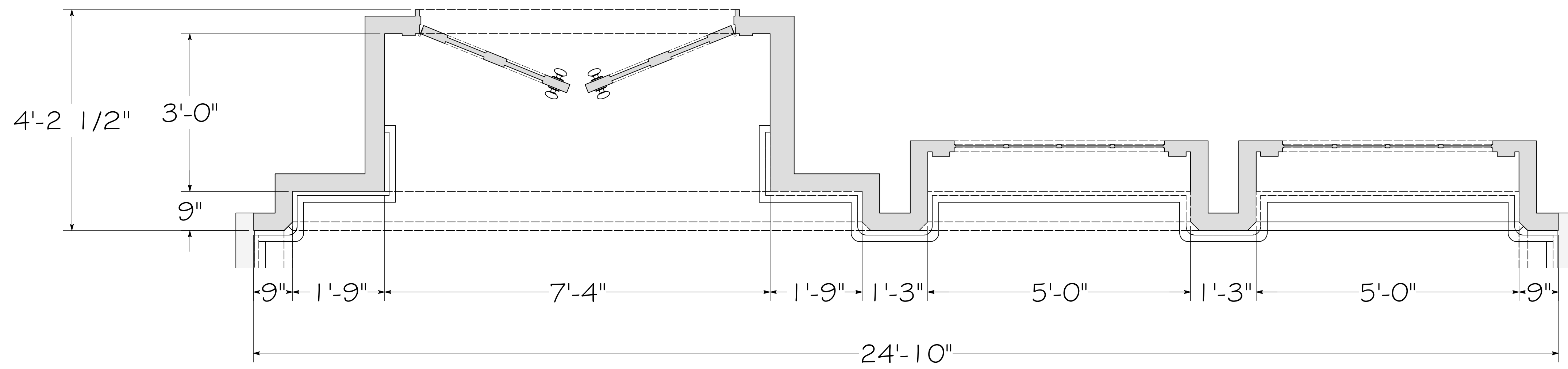

FLAT C PLAN  
SCALE: 3/4" = 1' - 0"

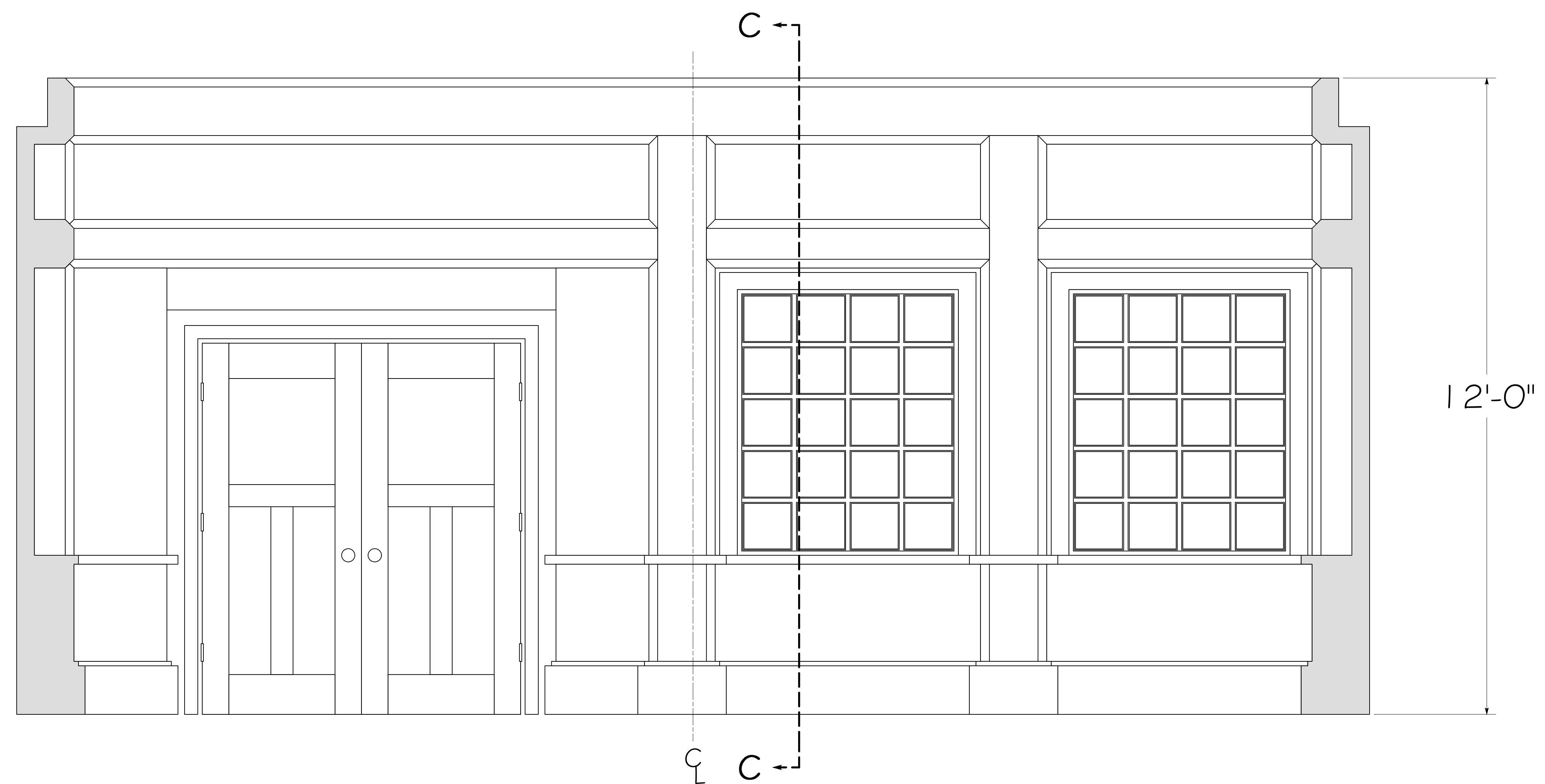

FLAT C ELEVATION  
SCALE: 3/4" = 1' - 0"

NOTE: TYPICAL BASE BOARD, CHAIR RAIL, DOOR PANEL, DOOR AND WINDOW MOLDING, AND MUNTIN AND MULLION MOLDING ARE ALL FLAT. ALL (EXCEPT FOR MUNTIN AND MULLION) HAVE A 1/4" ROUND OVER EDGE. -ALL SURFACES APPEAR AS AGED SPRUCE WOOD. SAND BLASTING SURFACES TO BRING OUT TEXTURE IS RECOMMENDED.

3/4" = 1' - 0"  
UNLESS OTHERWISE NOTED

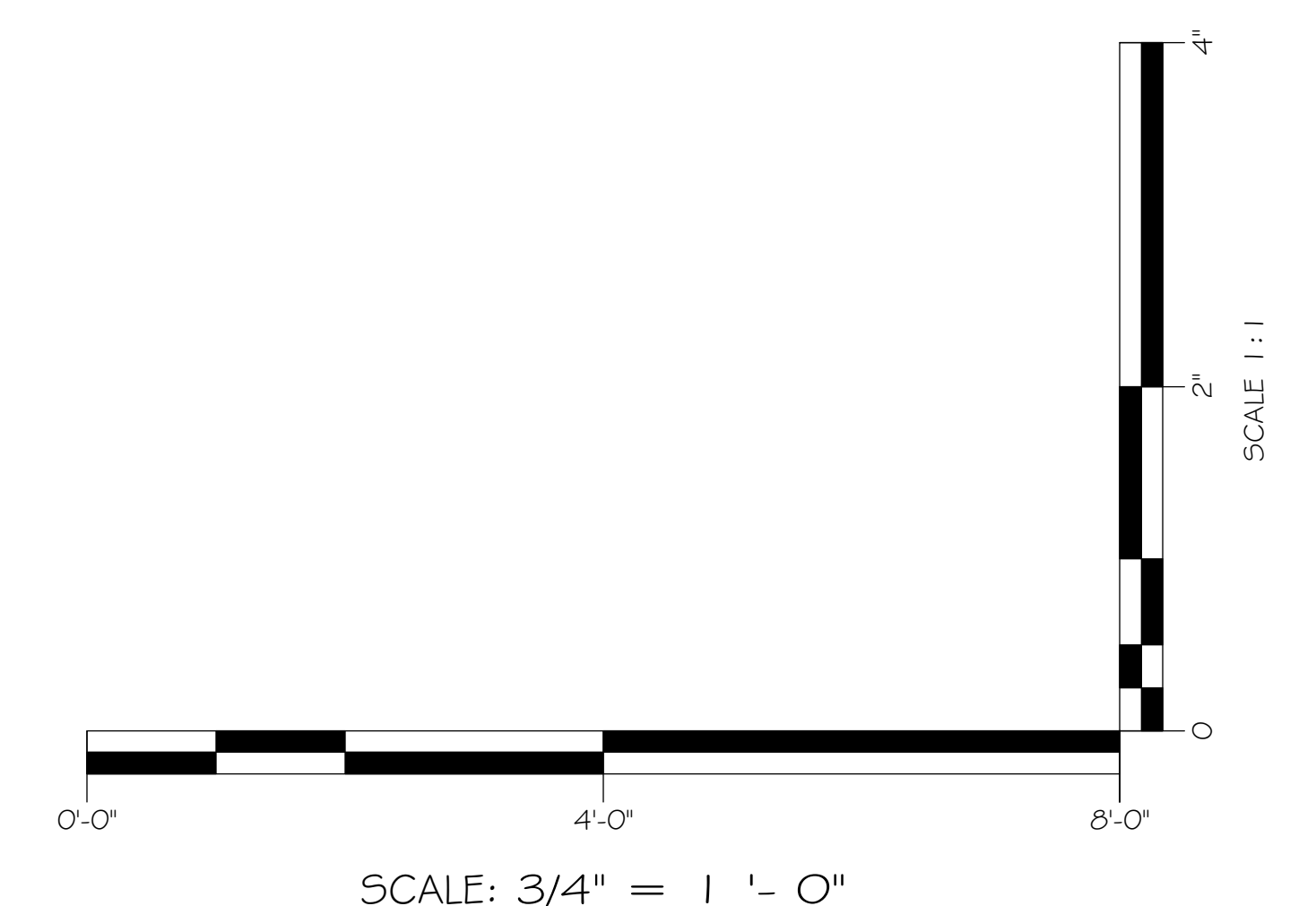

FLAT C ELEVATION

MARX THEATRE

DESIGNED BY CARI NOEL PROFESSOR

JOE TILFORD

SCALE: 3/4" = 1' - 0"

DRAWN ON 04.28.2020

THE CHERRY ORCHARD

PAGE

5

08

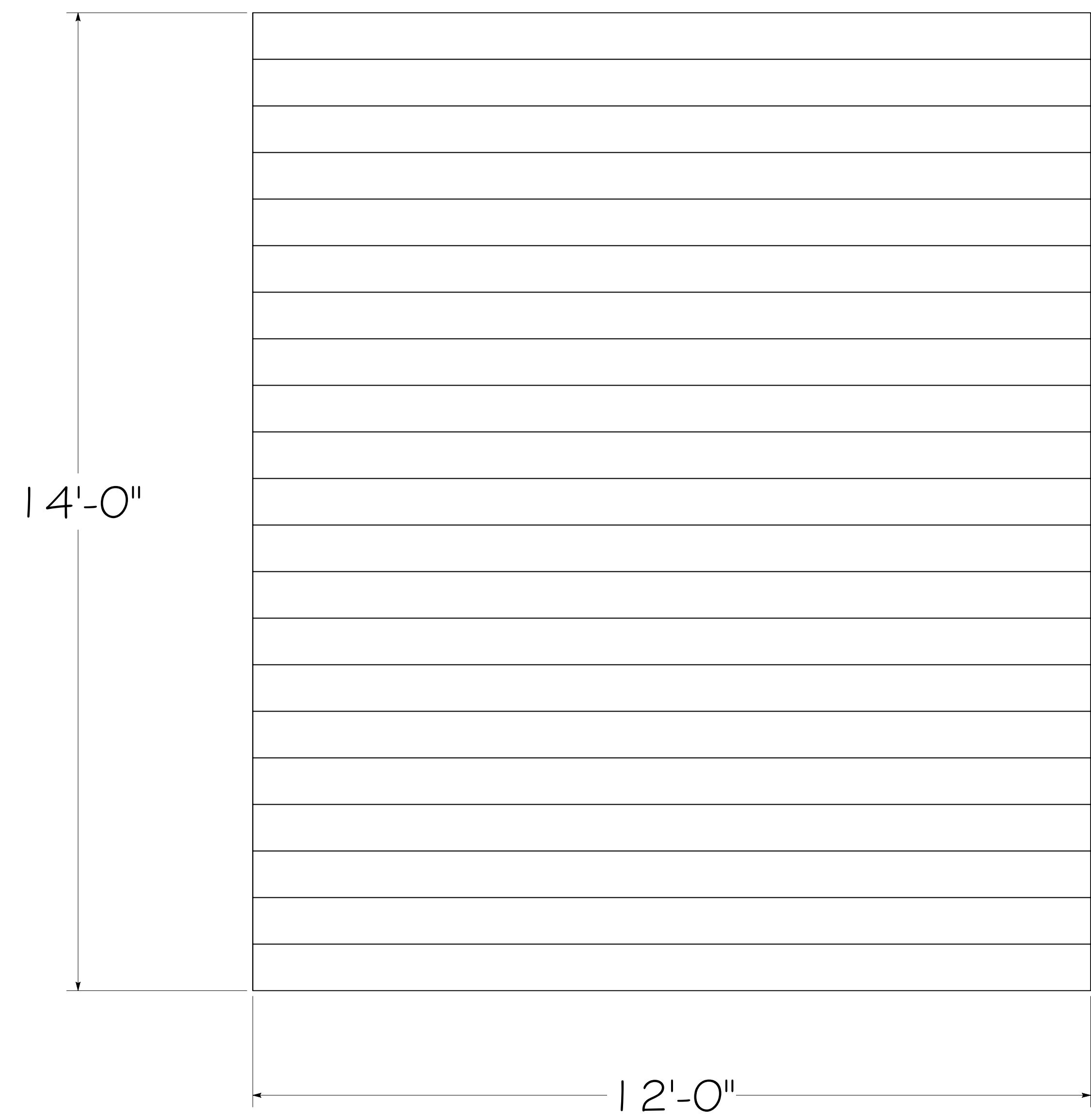

F FLAT F ELEVATION  
SCALE: 3/4" = 1' - 0"



G FLAT G ELEVATION  
SCALE: 3/4" = 1' - 0"



H FLAT H ELEVATION  
SCALE: 3/4" = 1' - 0"

3/4" = 1' - 0"  
UNLESS OTHERWISE  
NOTED

SCALE: 3/4" = 1' - 0"

DRAWN ON 04.28.2020

GROUND PLAN

MARX THEATRE

DESIGNED BY

CARI NOEL

PROFESSOR

JOE TILFORD

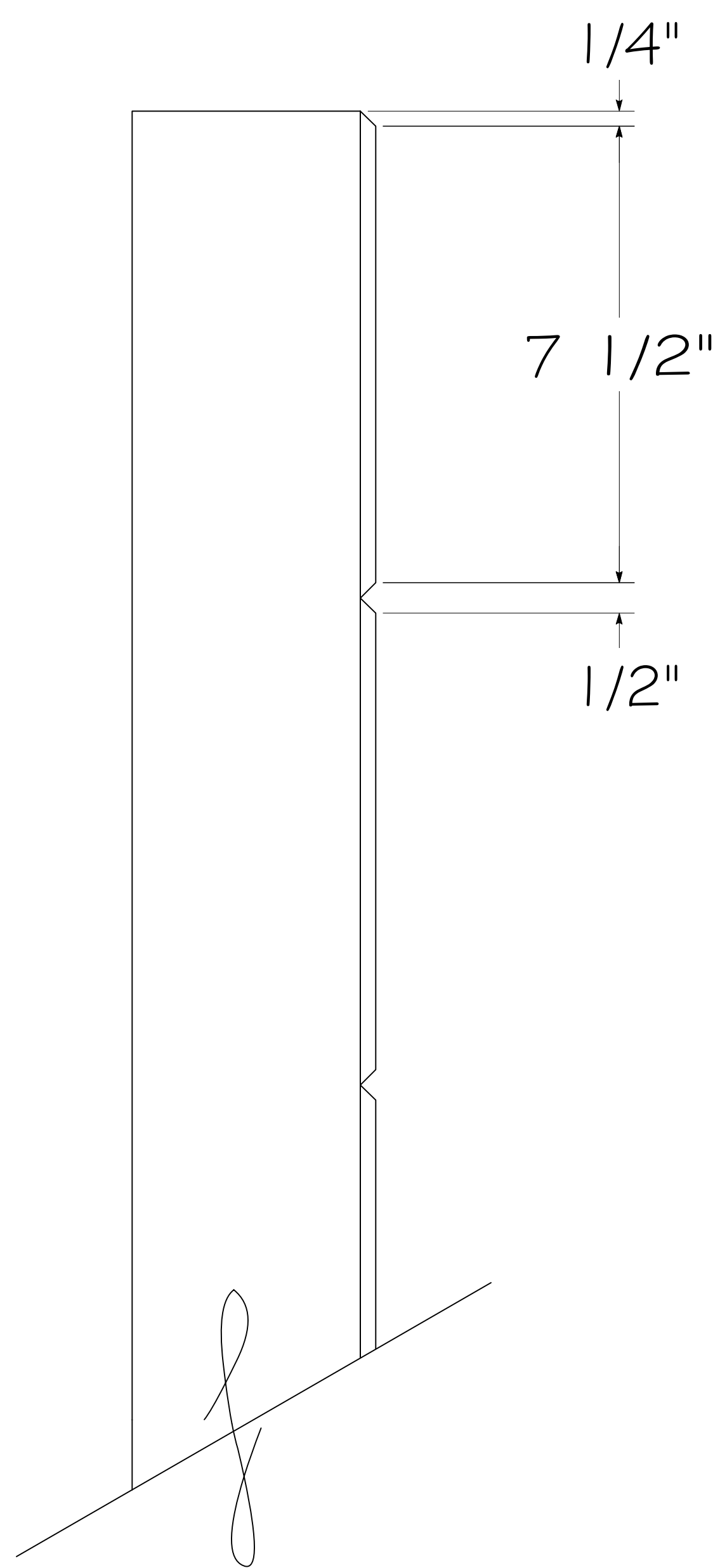

TYP. MASKING FLAT CHAMFER DETAIL  
SCALE: 1:2

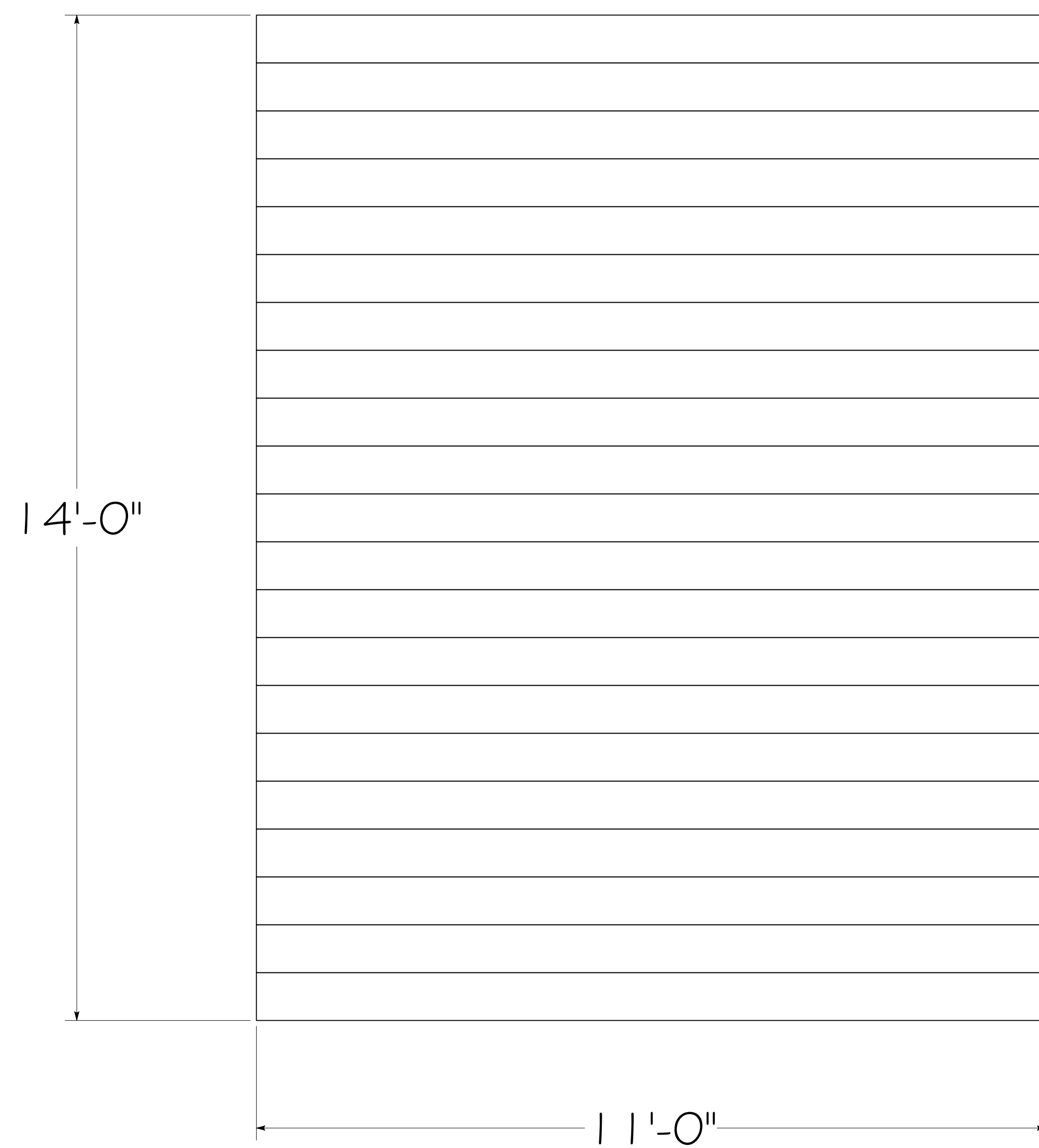

J FLAT J ELEVATION  
SCALE: 3/4" = 1' - 0"



K FLAT K ELEVATION  
SCALE: 3/4" = 1' - 0"



L FLAT L ELEVATION  
SCALE: 3/4" = 1' - 0"

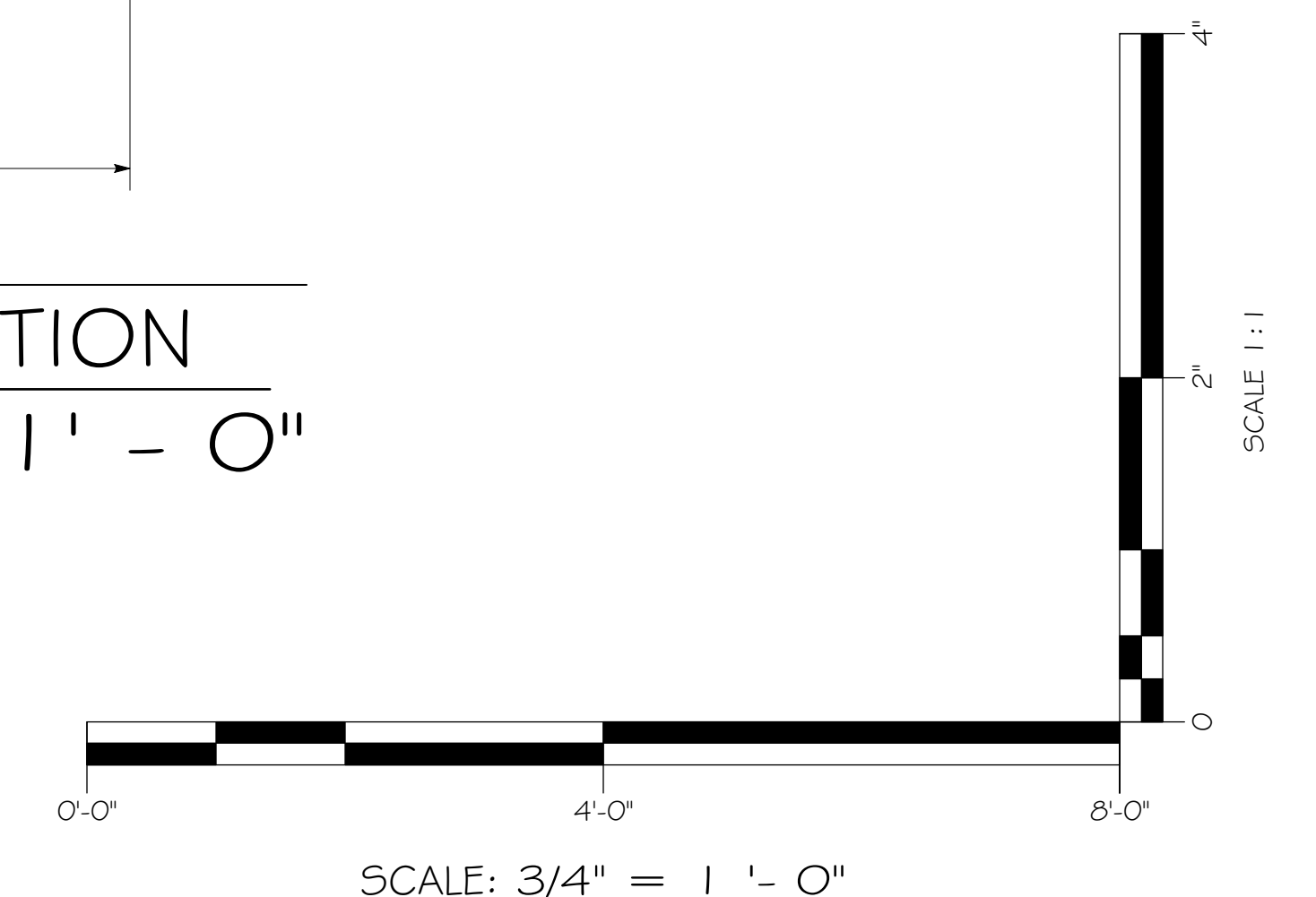
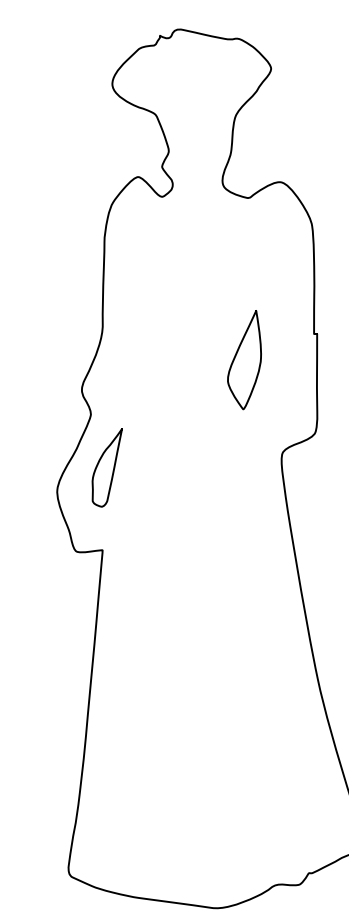

THE CHERRY ORCHARD

PAGE

6

8

3/4" = 1' - 0"  
UNLESS OTHERWISE  
NOTED

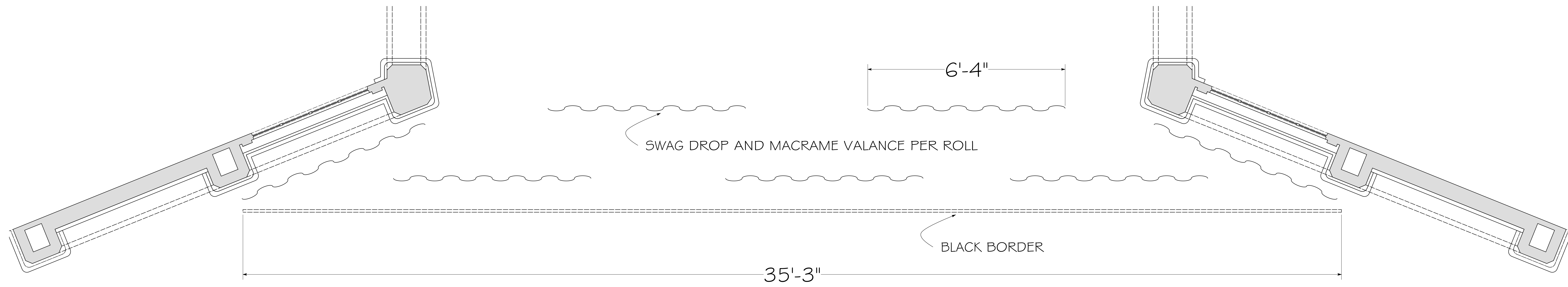

(M) ROLL DROP PLAN  
SCALE: 3/4" = 1' - 0"

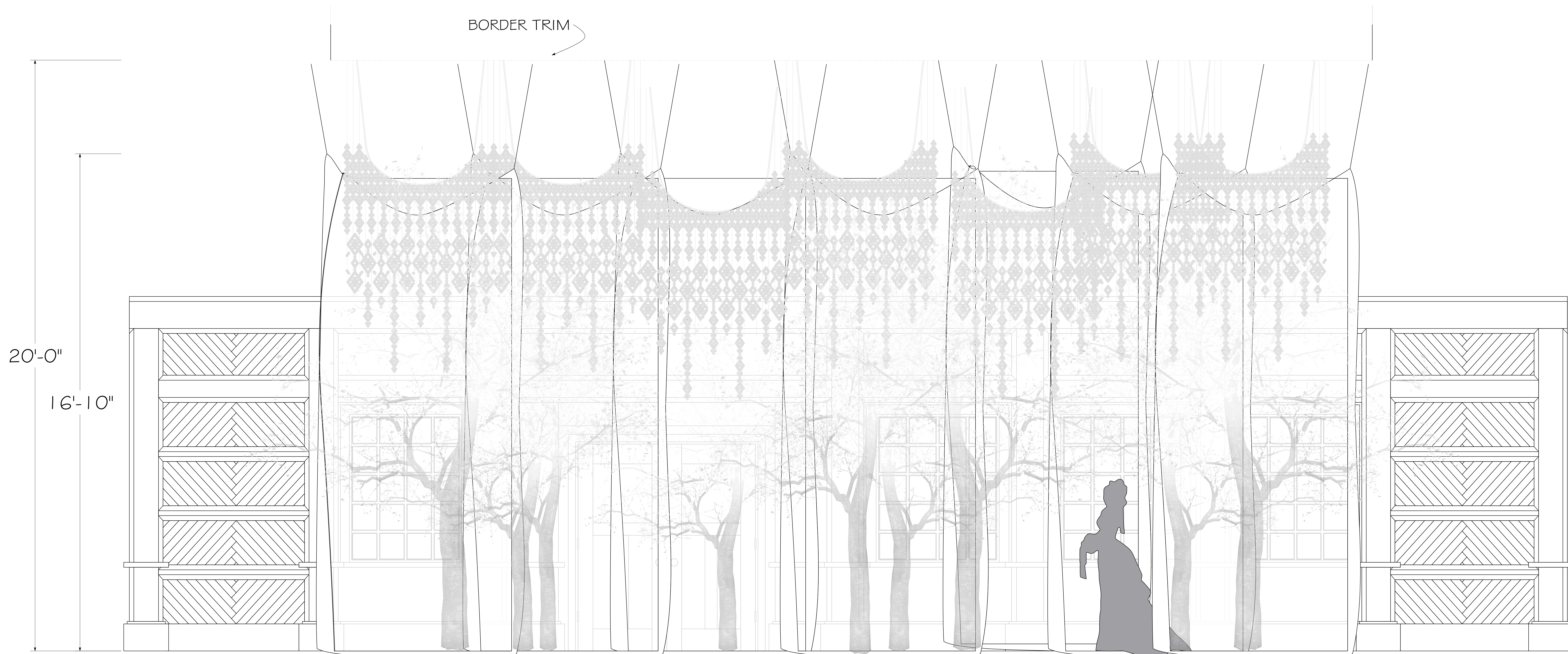

(M) ACT 2 ELEVATION  
SCALE: 3/4" = 1' - 0"

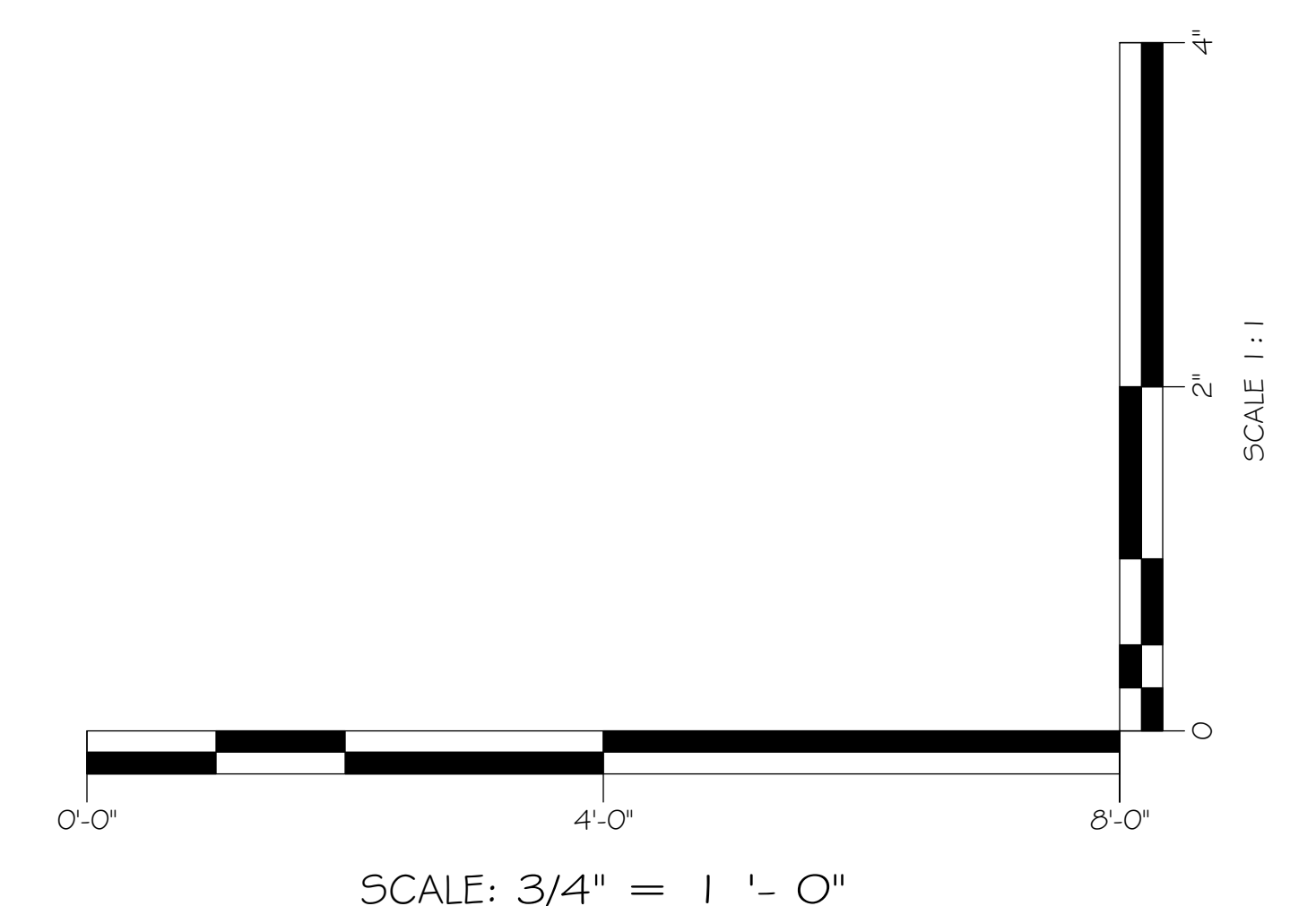

ROLL DROP DRAWING M

MARX THEATRE

DESIGNED BY CARI NOEL

PROFESSOR

JOE TILFORD

SCALE: 3/4" = 1' - 0"

DRAWN ON 04.28.2020

THE CHERRY ORCHARD

PAGE

7

08

EACH DROP SHOULD HAVE A WIDTH OF ROUGHLY 8 FEET TO ALLOW BILLOWING, FULLNESS, AND SOME SWAG AT THE TOP. THE TECHNICAL DIRECTOR WILL NEED TO ADVISE HOW MUCH WIDTH IS LOST WHEN DRAPED. THE END RESULT SHOULD BE SIMILAR TO THIS REFERENCE.

BLACK BORDER TRIM HEIGHT

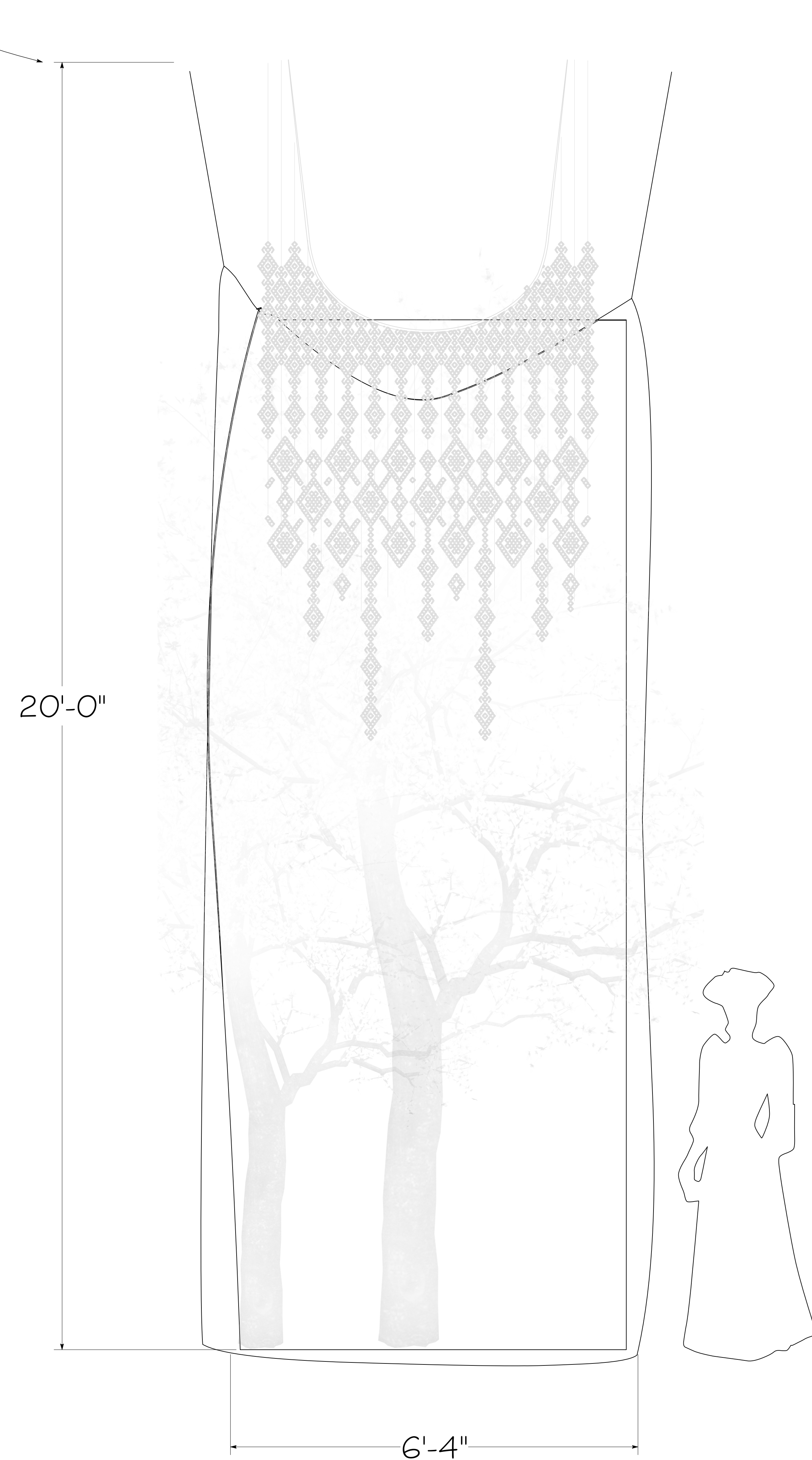

(M) ACT 2 ROLL DROP (MAKE 7)  
SCALE: 1" = 1' - 0"

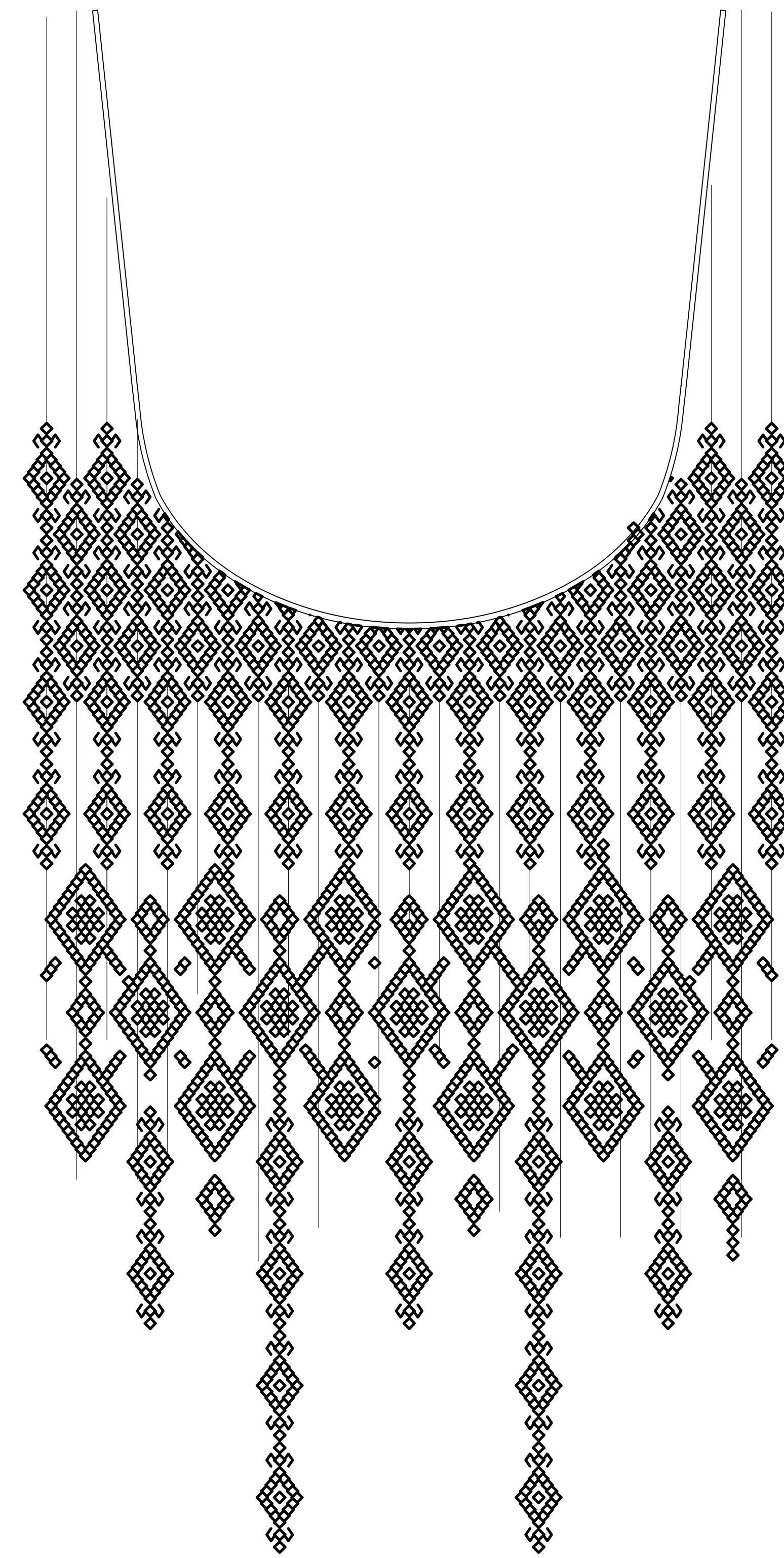

FOR REFERENCE ONLY. CONSTRUCTION TO BE DISCUSSED WITH THE TECHNICAL DIRECTOR. DRAWING REPRESENTS THE END RESULT DIMENSIONS. ESTIMATED COMPRESSION IS 2'-0"

(M) DETAIL OF MACRAME VALANCE  
SCALE: 1 1/2" = 1' - 0"

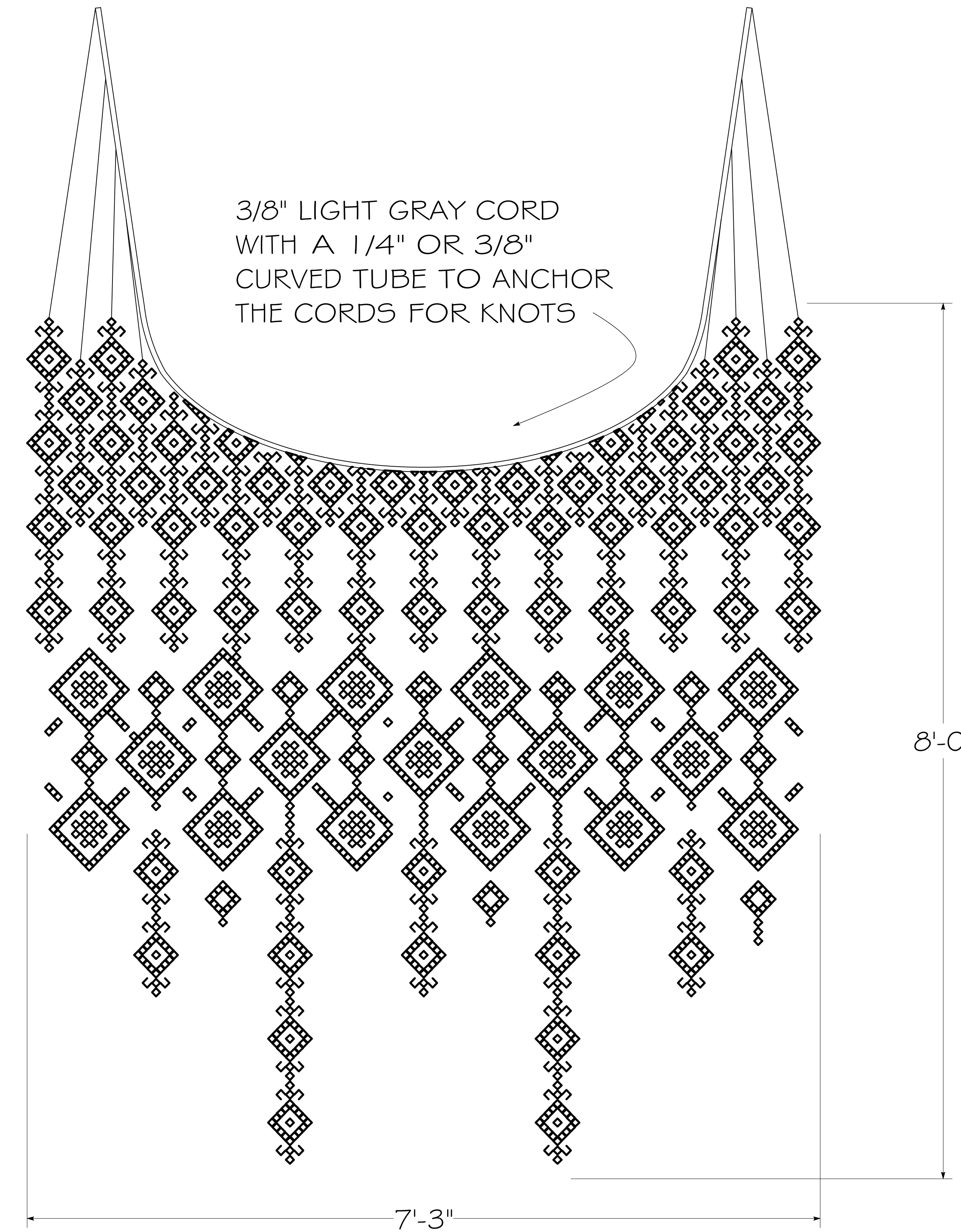

FOR REFERENCE ONLY. CONSTRUCTION TO BE DISCUSSED WITH THE TECHNICAL DIRECTOR. DRAWING REPRESENTS THE PATTERN OF KNOTS TO FOLLOW.

(M) TRUE VIEW OF MACRAME VALANCE  
SCALE: 1 1/2" = 1' - 0"

NOTE: AT THE DETERMINED TIME, THE SHEER FABRIC FALLS KABUKI STYLE AND THE MACRAME VALANCE FLIES (ROLLS) BACK OUT.

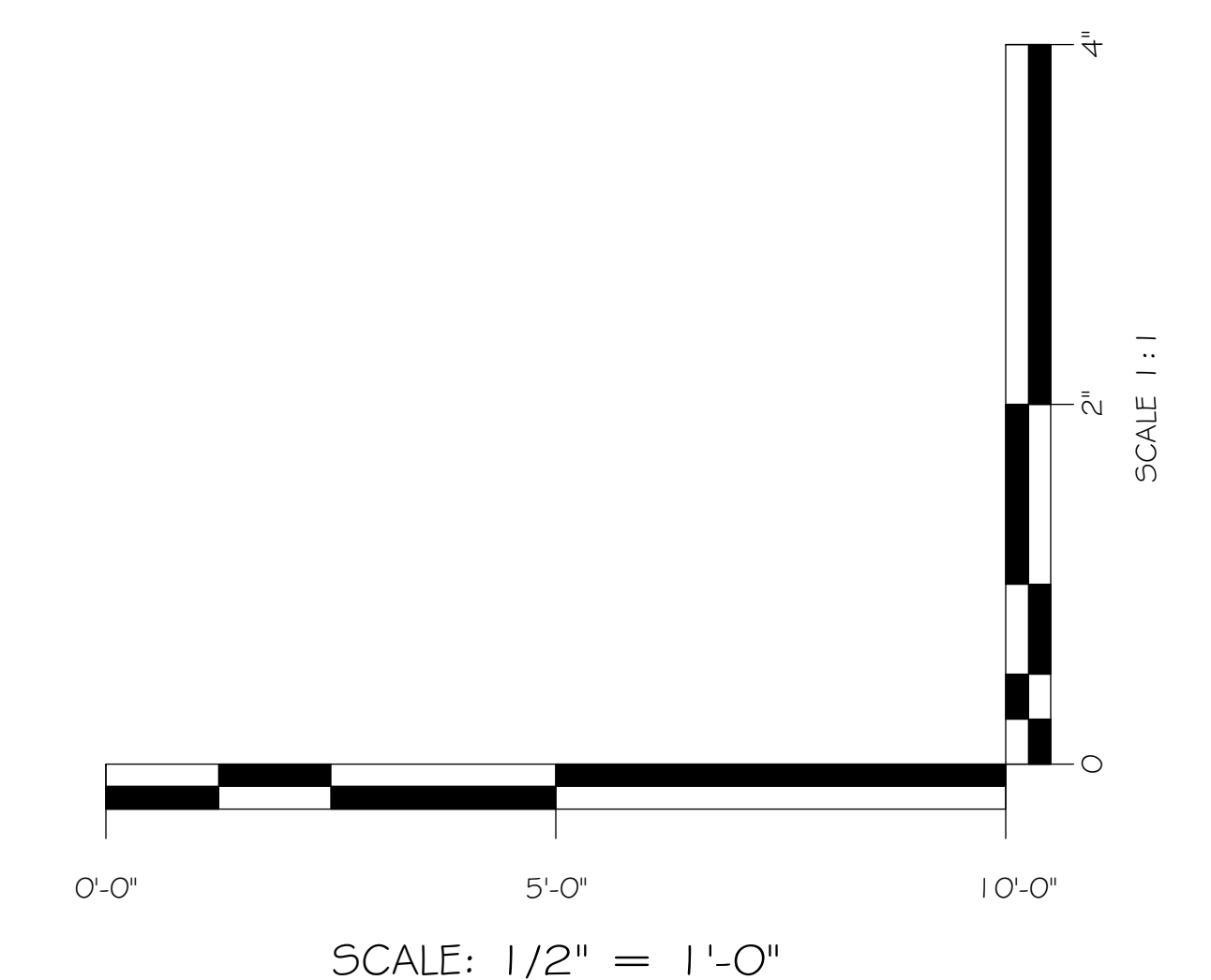

SCALE: SEE DRAWING  
DRAWN ON 04.28.2020

ROLL DROP DETAILS  
MARX THEATRE  
DESIGNED BY CARI NOEL  
PROFESSOR JOE TILFORD

THE CHERRY ORCHARD

PAGE

