

1 GROUND PLAN
 Scale: 1/2" = 1'-0"

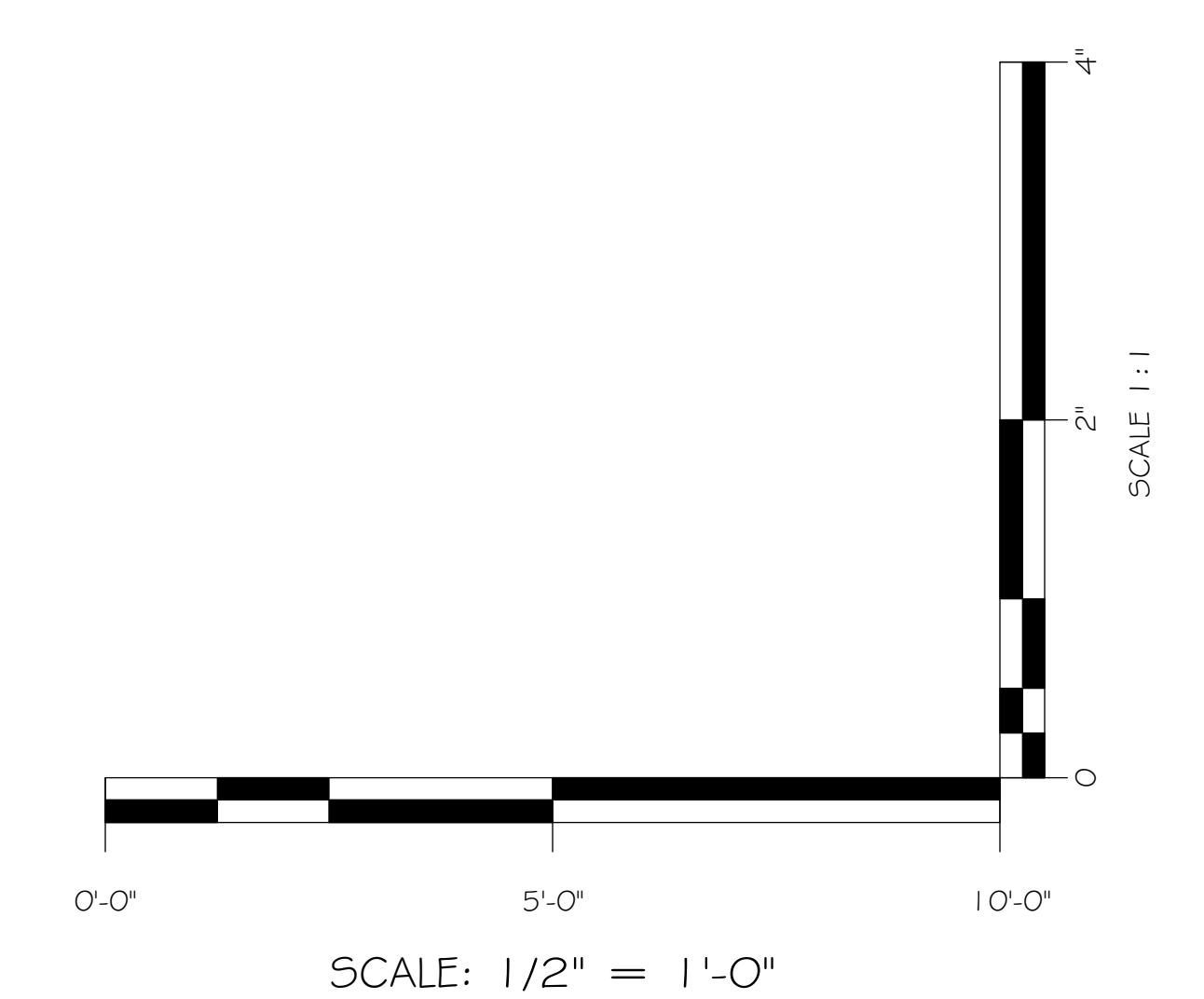

SCALE 1/2" = 1'-0"	GROUND PLAN	DESIGNED BY CARI NOEL	PROFESSOR
DRAWN ON 05.08.2020	NEW FREEDMAN THEATRE	JOHN COYNE	
ROMEO & JULIET			
PAGE			
1			
	6		

LINESSET TRIMS ARE SHOWN IN THEIR HARD STOP, IN POSITION.
 TRIM HEIGHTS OF EACH FLAT WILL VARY BY SCENE
 TWO-AXIS PER LINESSET, VERTICAL AND HORIZONTAL: POSSIBLY A COMPENSATOR ON A STANDARD
 COUNTERWEIGHT SYSTEM OR A WINCH ON A TRAVELER, TO BE DISCUSSED WITH THE TECHNICAL DIRECTOR

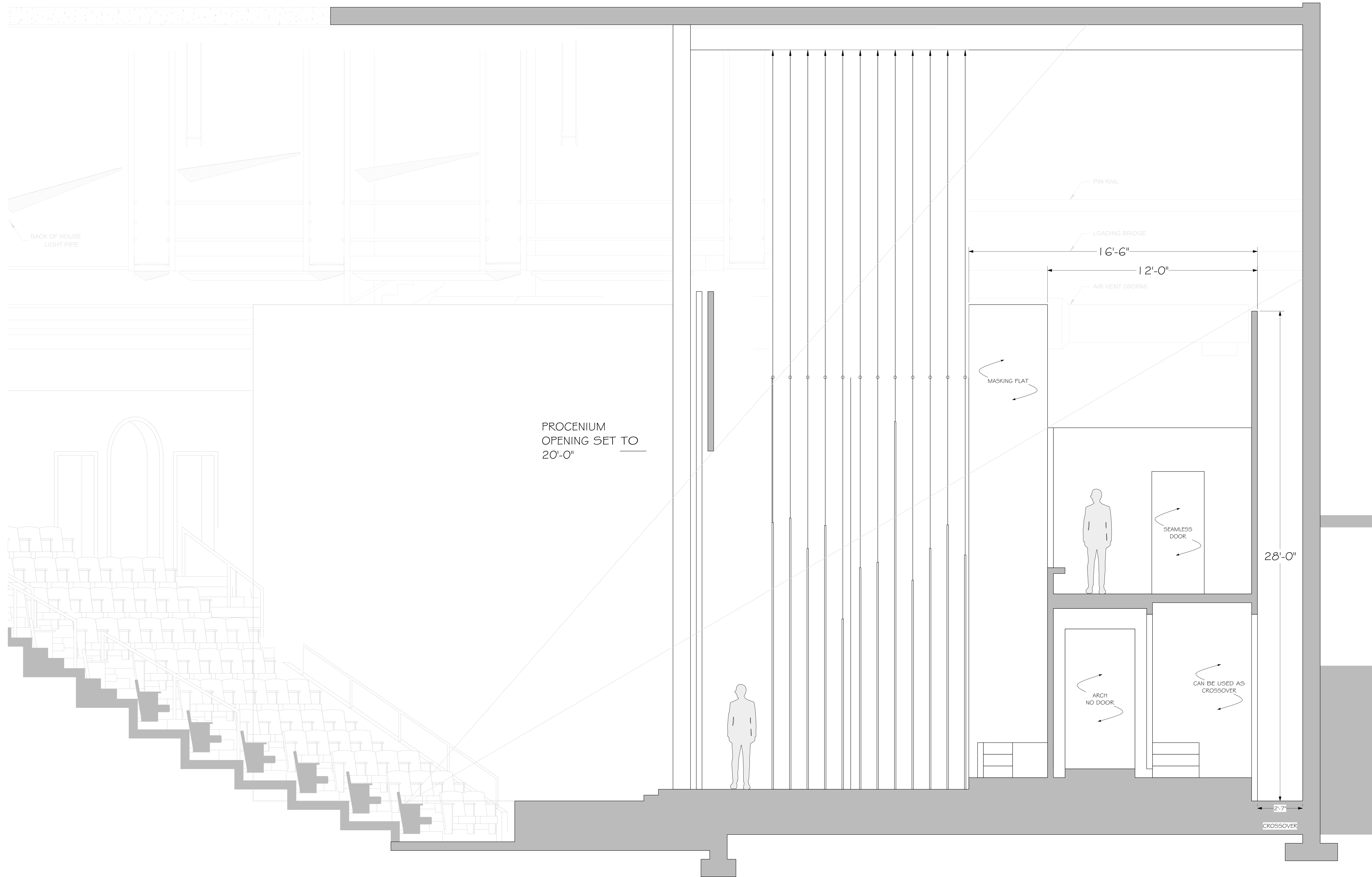

2 CENTERLINE SECTION
 Scale: 1/2" = 1'-0"

SUPPORTS FOR THE PLATFORMS, FLOATING STAIRS,
 AND TALL FLATS ARE NOT DETERMINED.
 WILL NEED TO BE DISCUSSED WITH THE TECHNICAL DIRECTOR

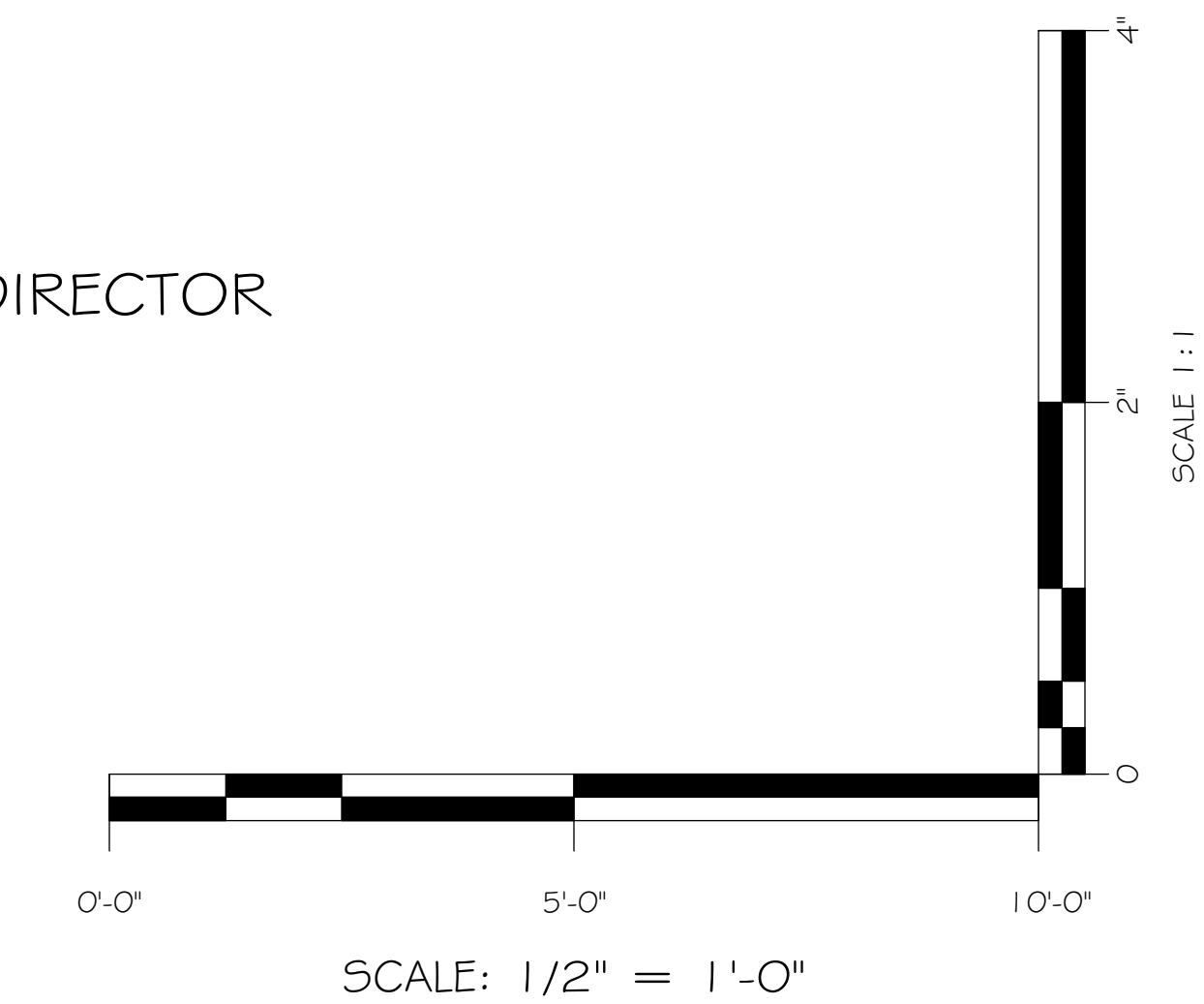

CENTERLINE SECTION LOOKING SR
 NEW FREEDMAN THEATRE
 DESIGNED BY CARI NOEL PROFESSOR JOHN COYNE
 SCALE 1/2" = 1'-0"
 DRAWN ON 05.08.2020

ROMEO & JULIET

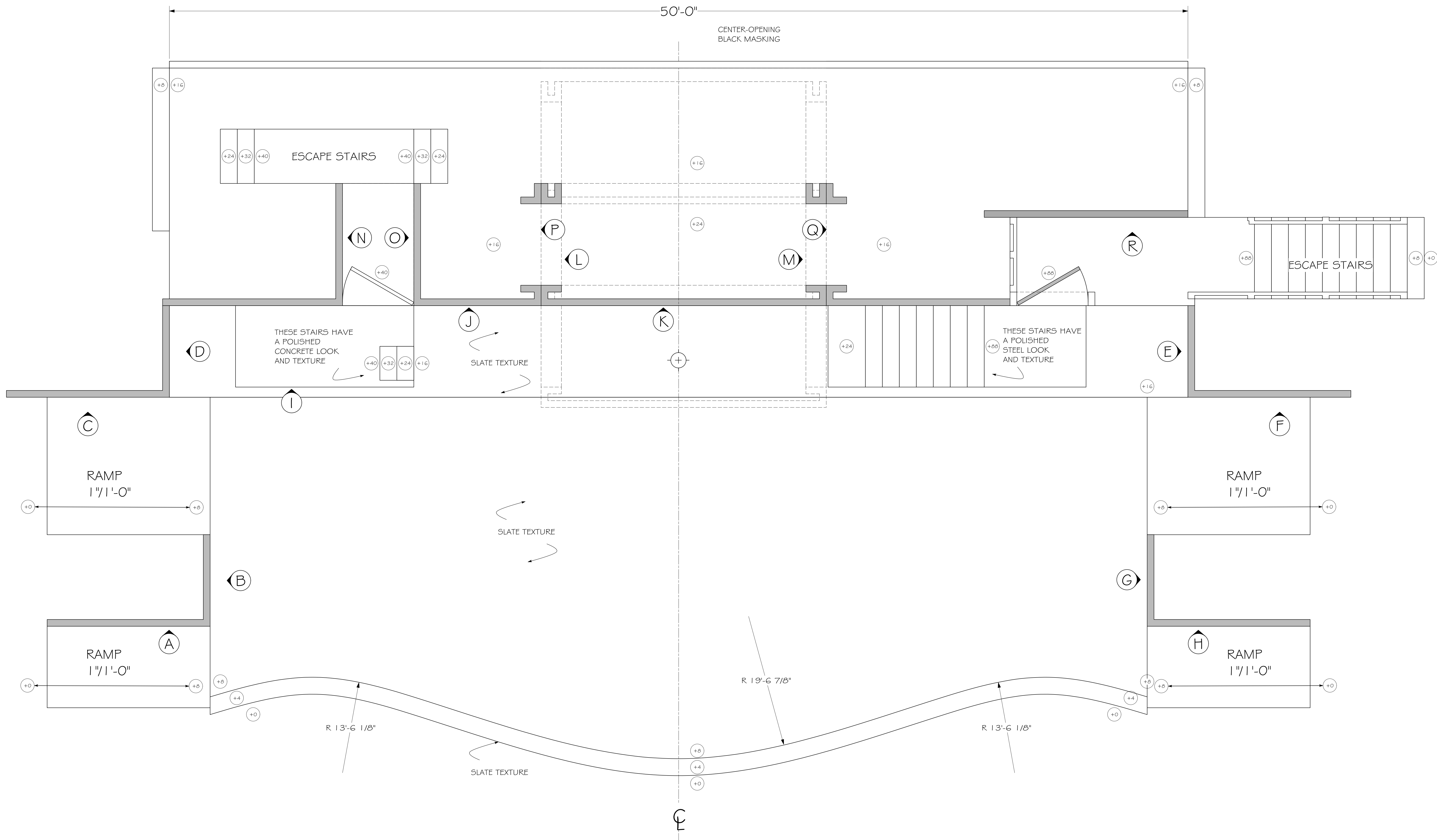

3 LOWER LEVELS PLAN
SCALE: 1/2" = 1'-0"

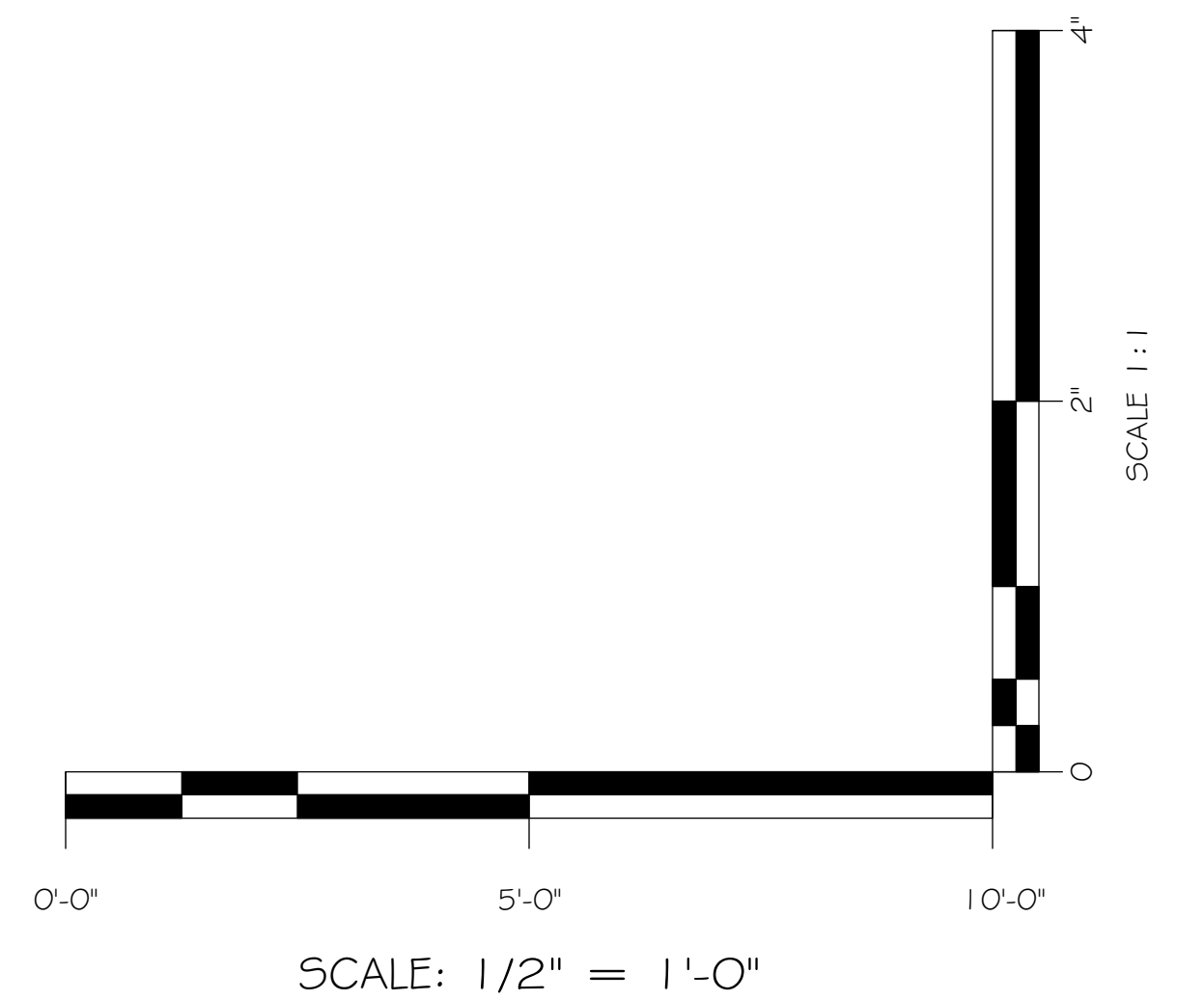

SCALE 1/2" = 1'-0"
DRAWN ON 05.08.2020

GROUND PLAN FOR LOWER LEVELS
NEW FREEDMAN THEATRE

DESIGNED BY CARI NOEL
PROFESSOR JOHN COYNE

ROMEO & JULIET

PAGE
3

6

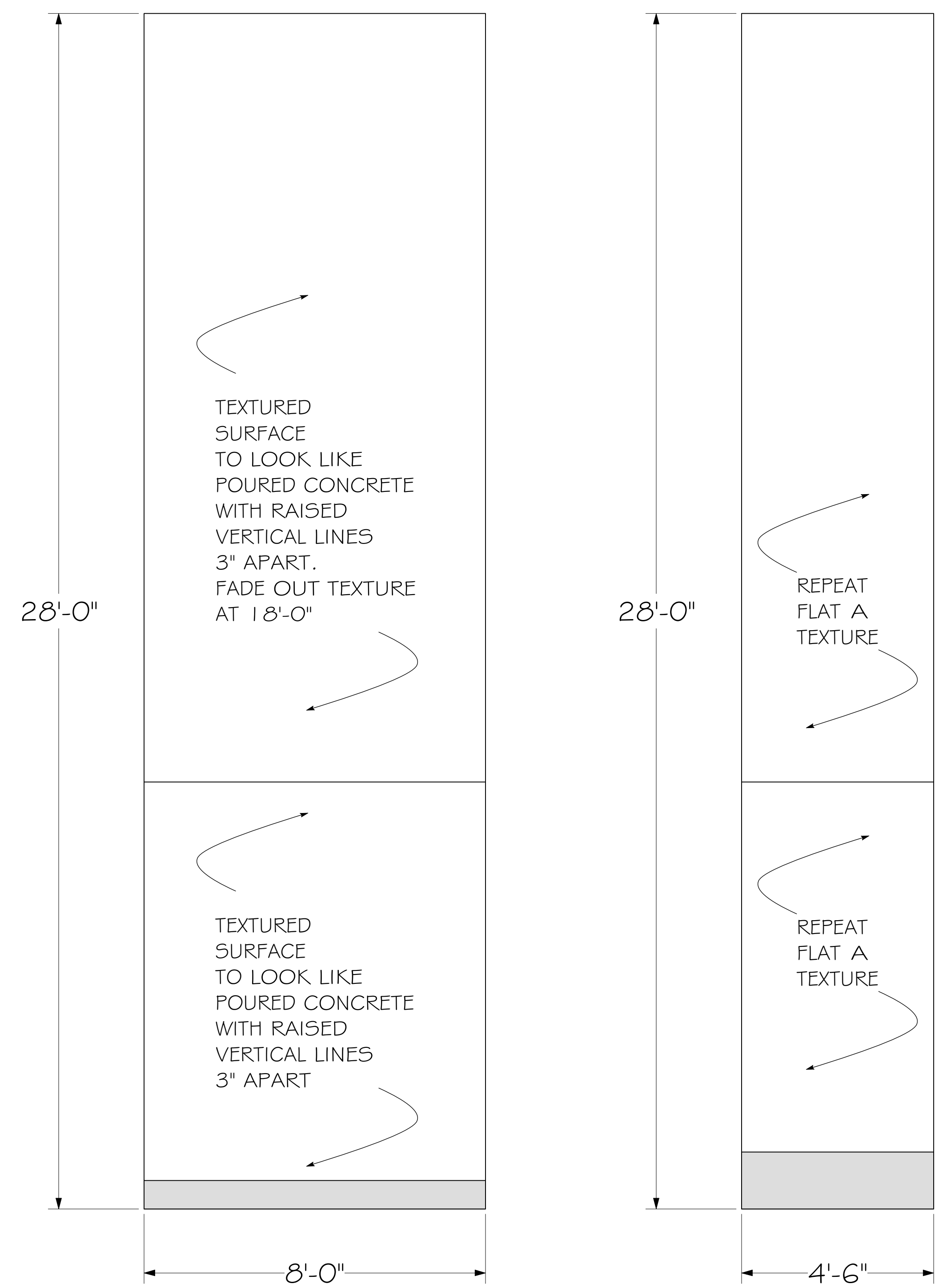

7 FLAT A & C
SCALE: 1/2" = 1'-0"

REVERSE AND REPEAT FLATS F & H

8 FLAT B & D
SCALE: 1/2" = 1'-0"

REVERSE AND REPEAT FLATS E & G

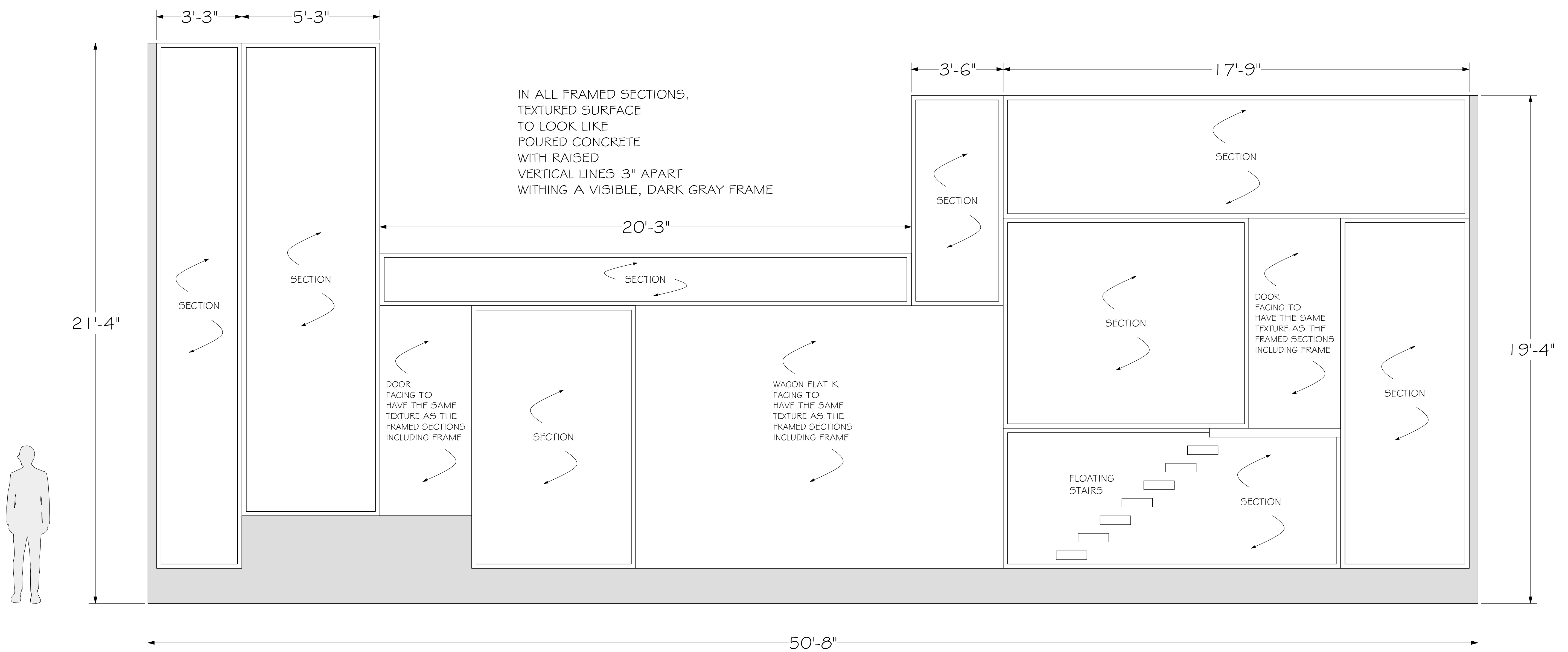

10 FLAT J
SCALE: 1/2" = 1'-0"

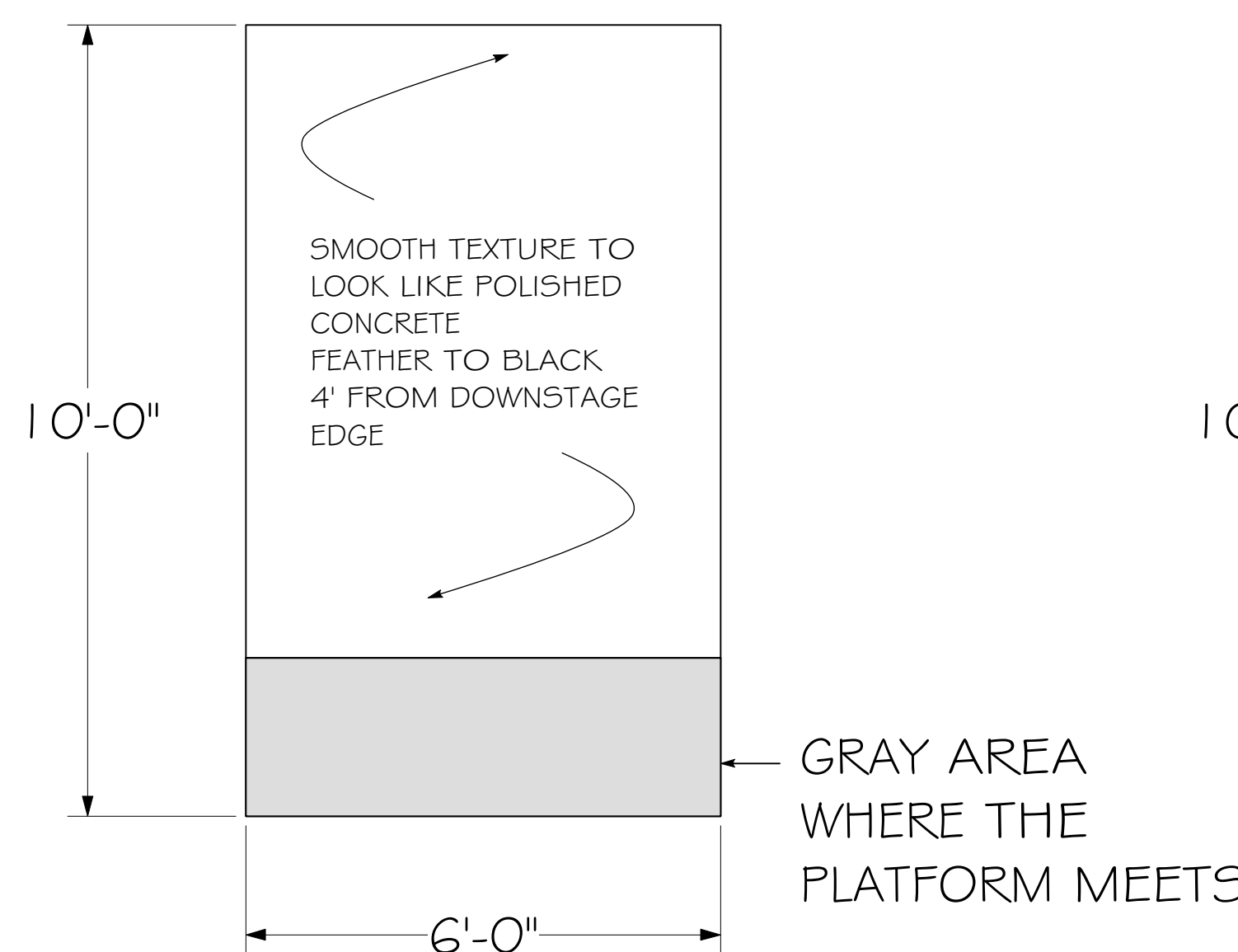

13 FLAT N
SCALE: 1/2" = 1'-0"

-REVERSE AND REPEAT FOR FLAT O
-DOOR REVEAL OVERHEAD SHOULD HAVE SAME TREATMENT ALSO

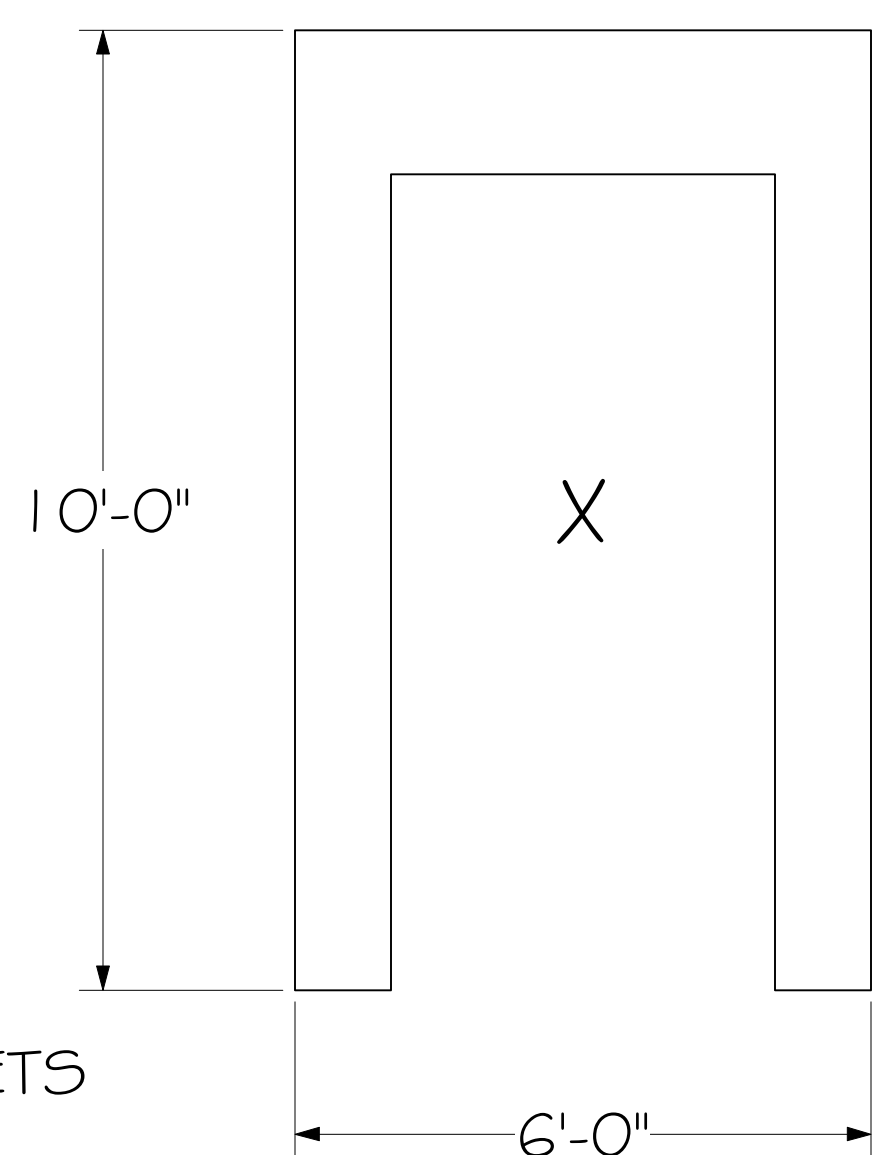

14 FLAT P
SCALE: 1/2" = 1'-0"

-REVERSE AND REPEAT FOR FLAT Q
-FIXED POSITION ARCHWAY WITH 1'-0" REVEAL
-SMOOTH TEXTURE PAINTED TO LOOK LIKE POLISHED CONCRETE

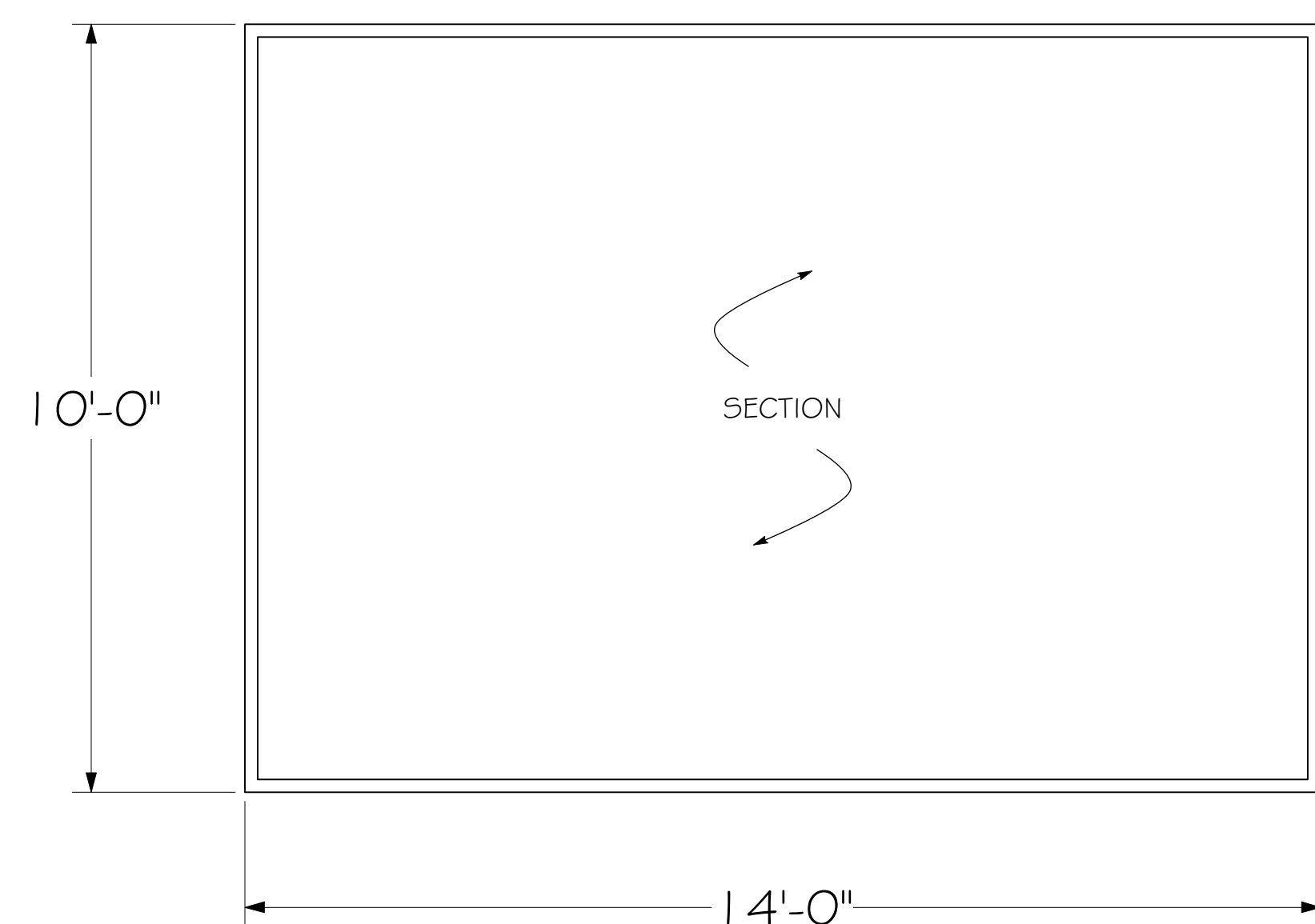

11 FLAT K
SCALE: 1/2" = 1'-0"

FLAT K, L & M ARE PART OF A FIXED CASTER WAGON THAT IS OPEN ON THE UPSTAGE SIDE FOR ENTRANCE/EXIT ACTOR ACCESS

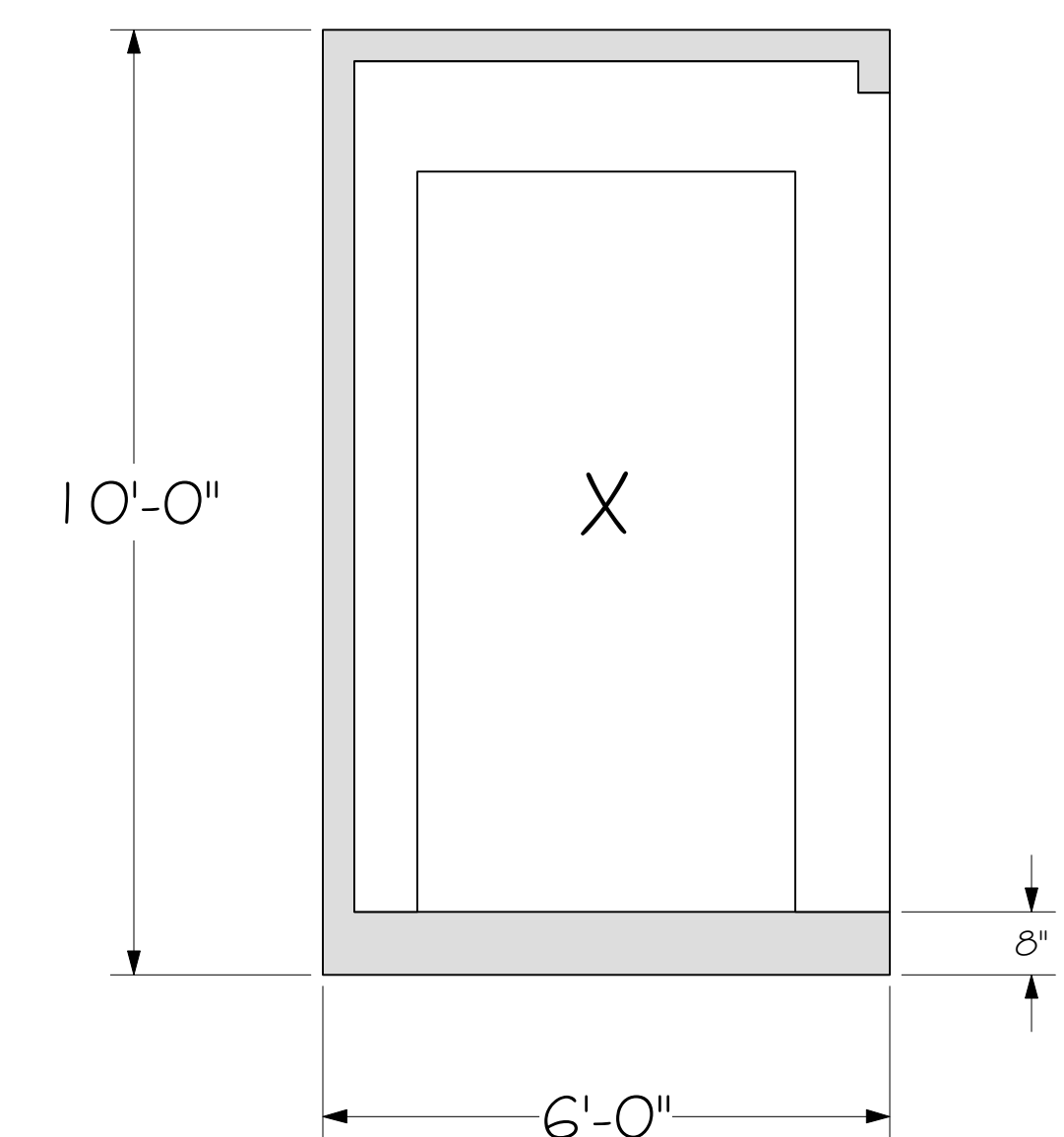

12 FLAT L
SCALE: 1/2" = 1'-0"

-SHOWING THE SECTION FROM INSIDE THE WAGON
-REVERSE AND REPEAT FOR FLAT Q
-OFFSTAGE FACE AND FACES THAT ARE VISIBLE TO THE AUDIENCE HAVE THE SAME TREATMENT AS FLAT P

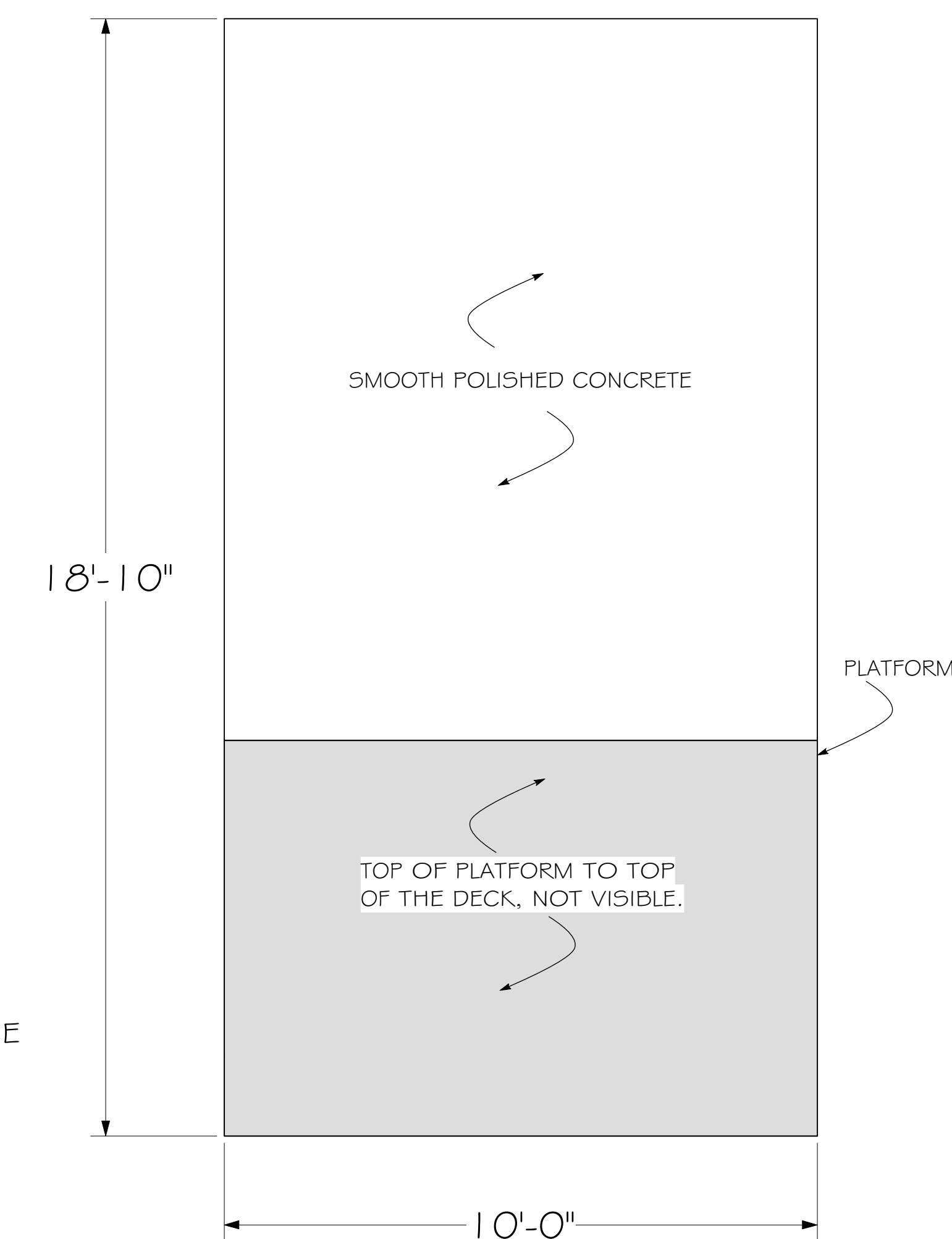

15 FLAT R
SCALE: 1/2" = 1'-0"

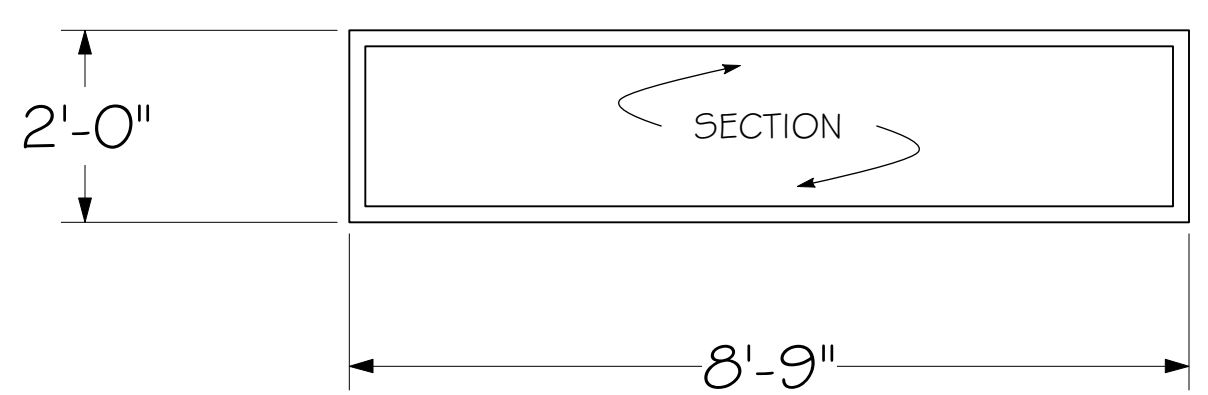

9 FLAT I
SCALE: 1/2" = 1'-0"

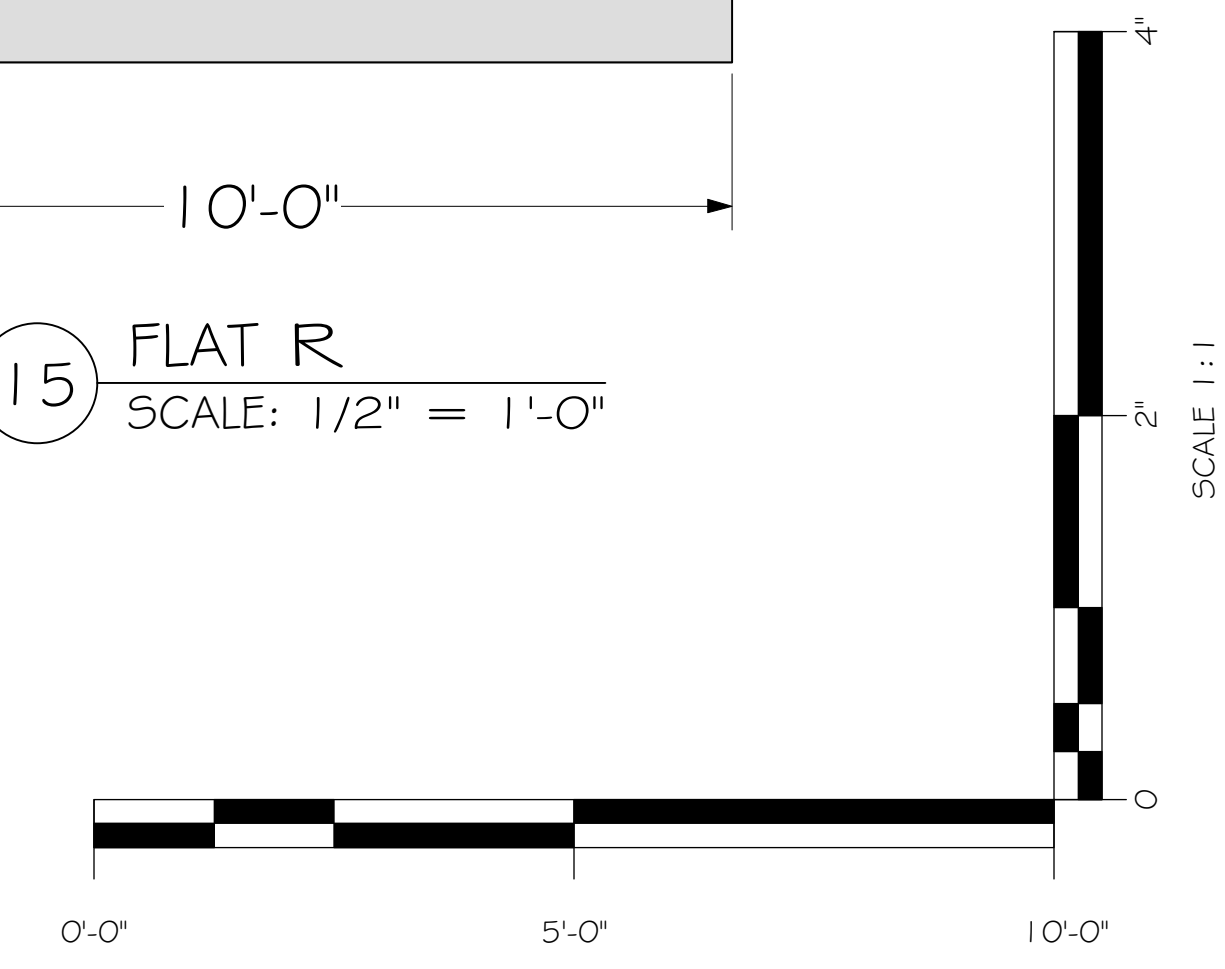

SCALE: 1/2" = 1'-0"

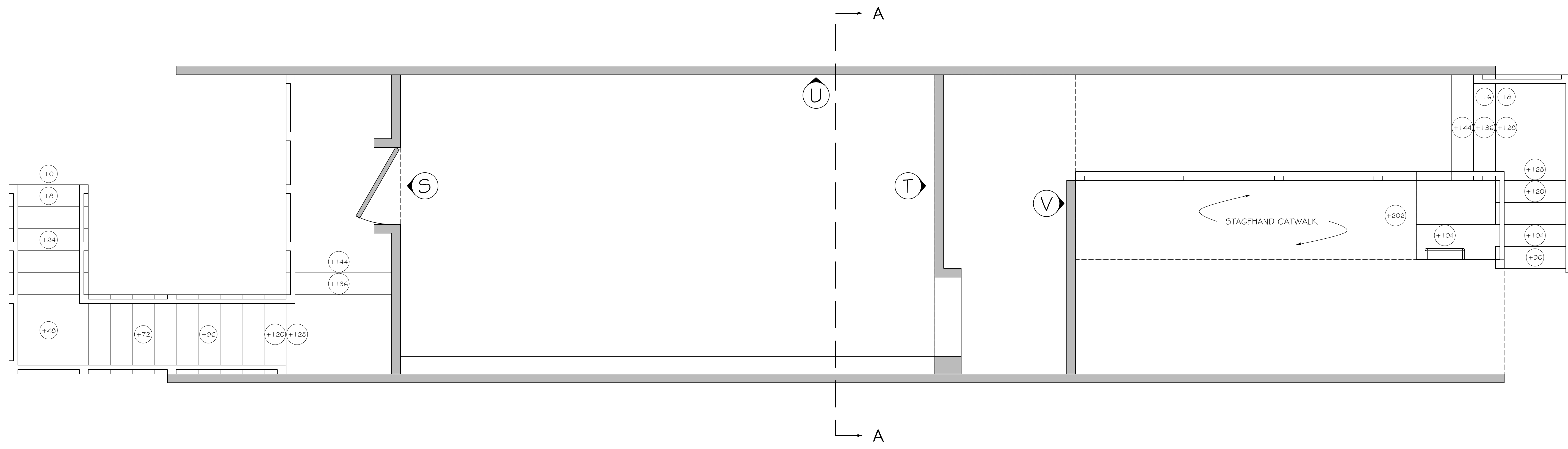

4 UPPER LEVELS
Scale: 1/2" = 1'-0"

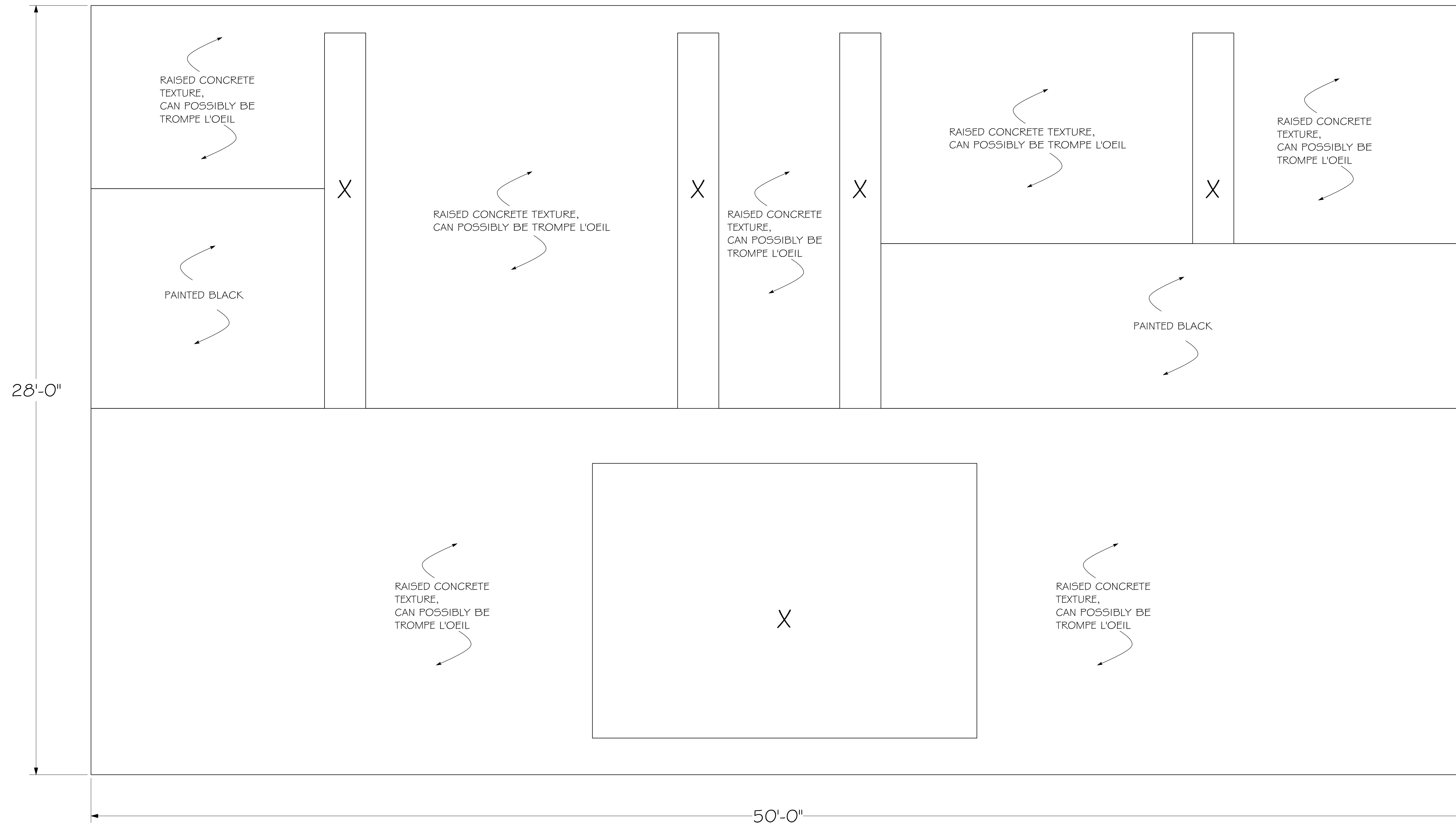

18 FLAT U
SCALE: 1/2" = 1'-0"

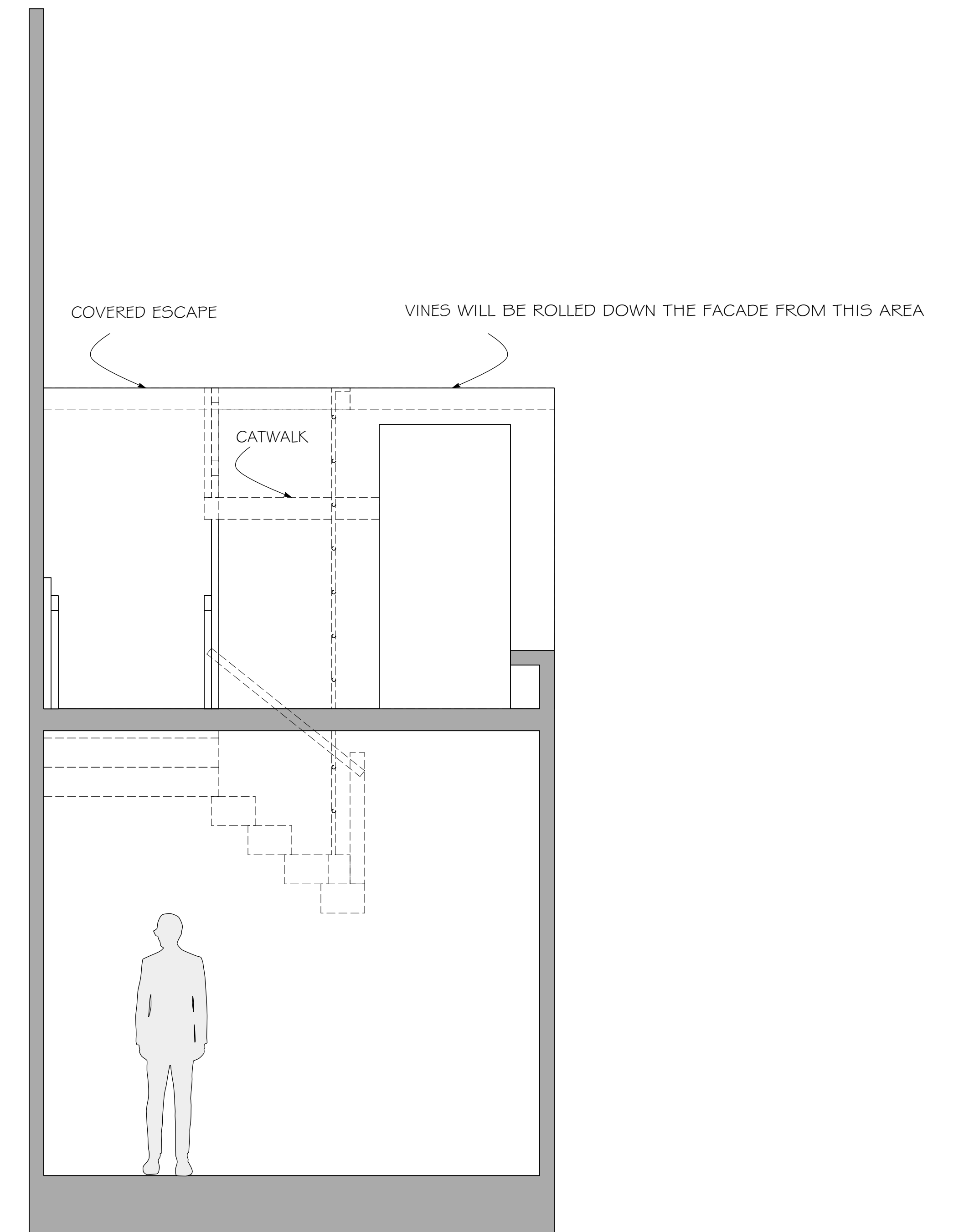

20 SECTION A-A
SCALE: 1/2" = 1'-0"

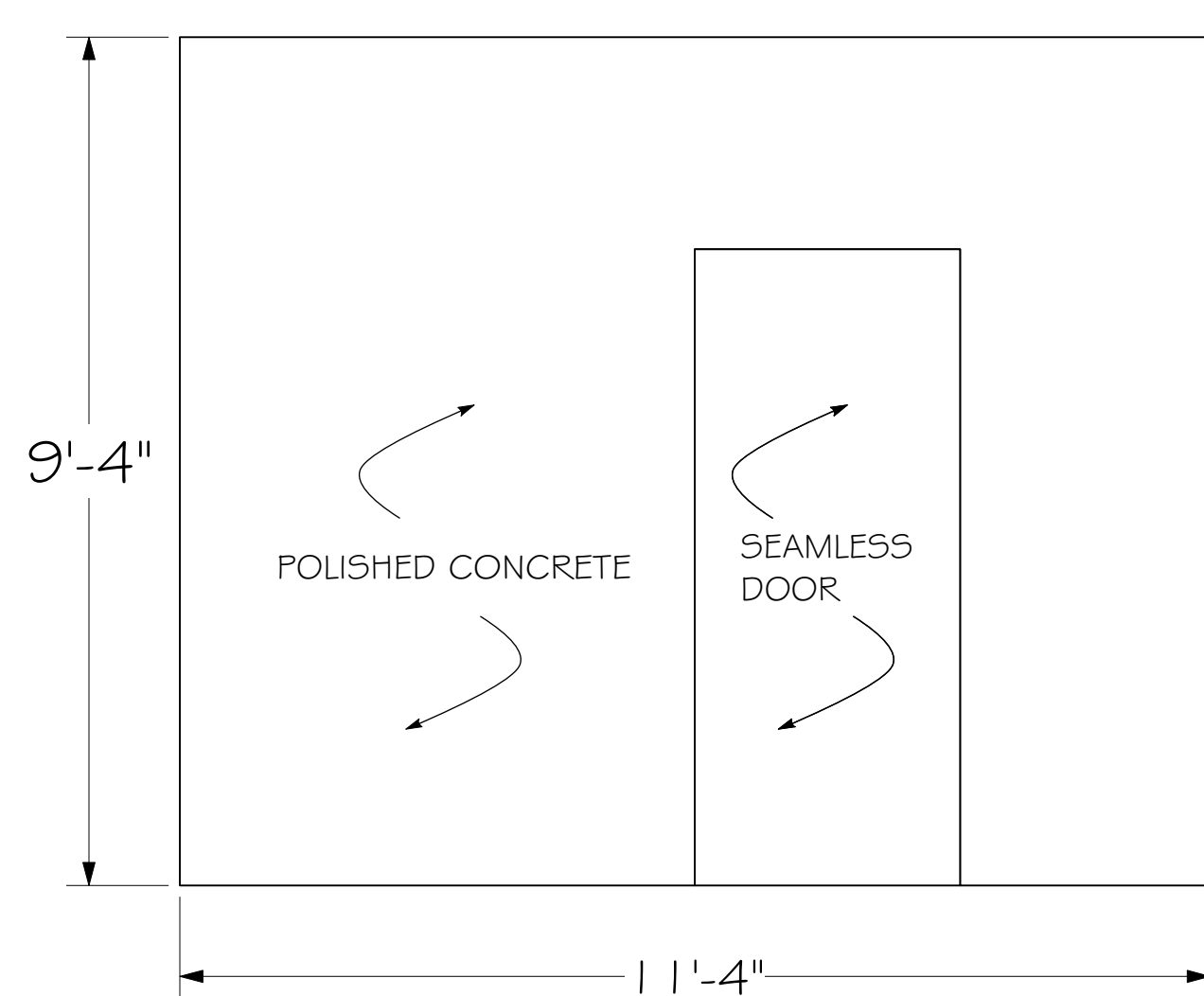

16 FLAT S
SCALE: 1/2" = 1'-0"

FLATS S & T
HAVE A 1' - 0" REVEAL WITH THE SAME TREATMENT

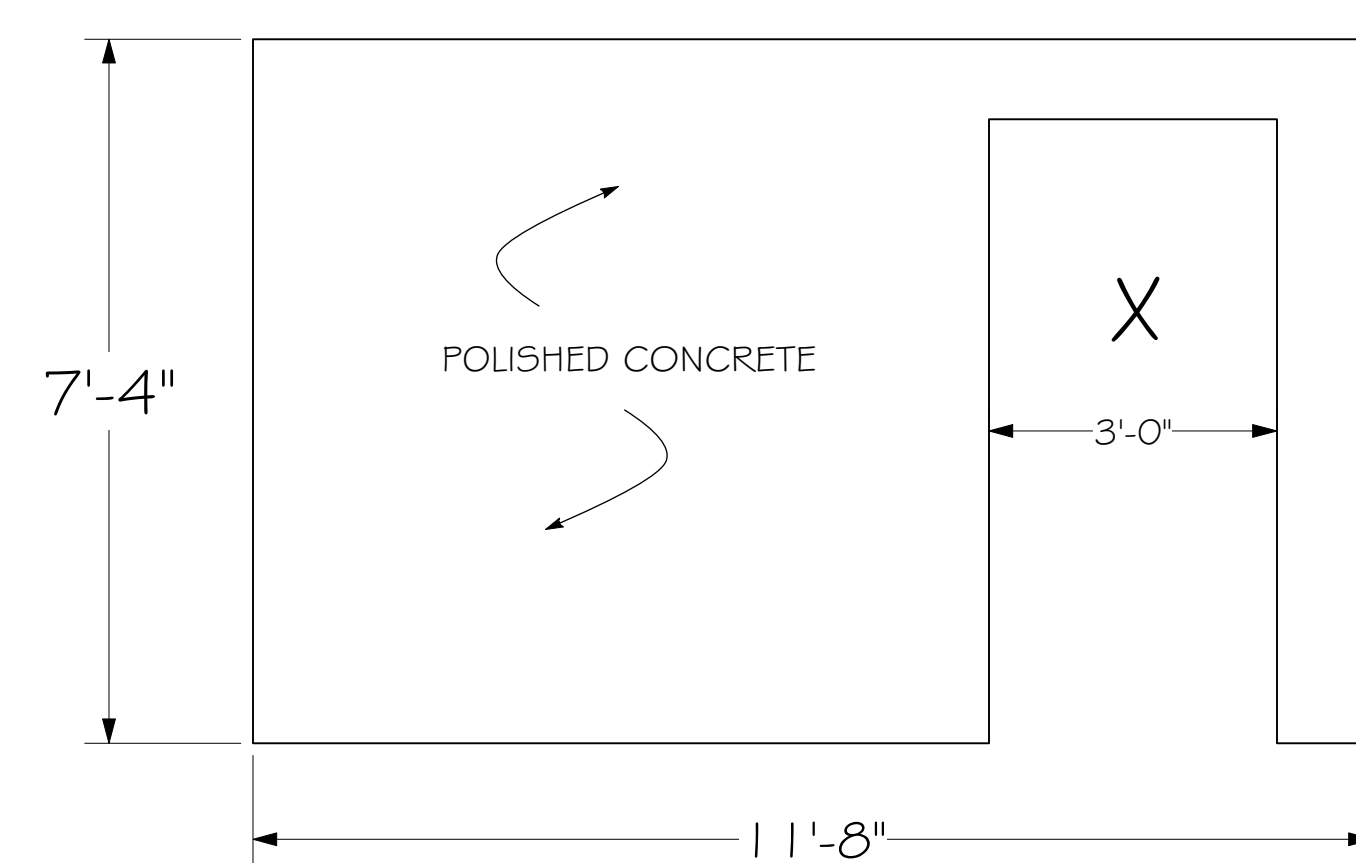

17 FLAT T
SCALE: 1/2" = 1'-0"

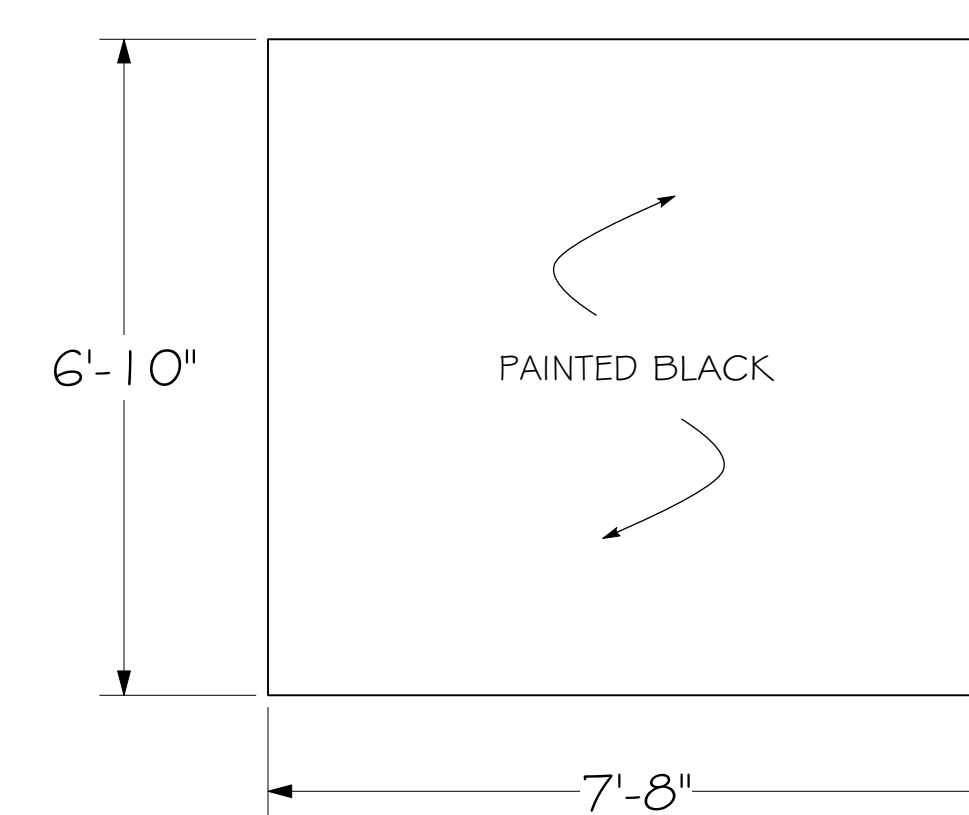

19 FLAT V
SCALE: 1/2" = 1'-0"

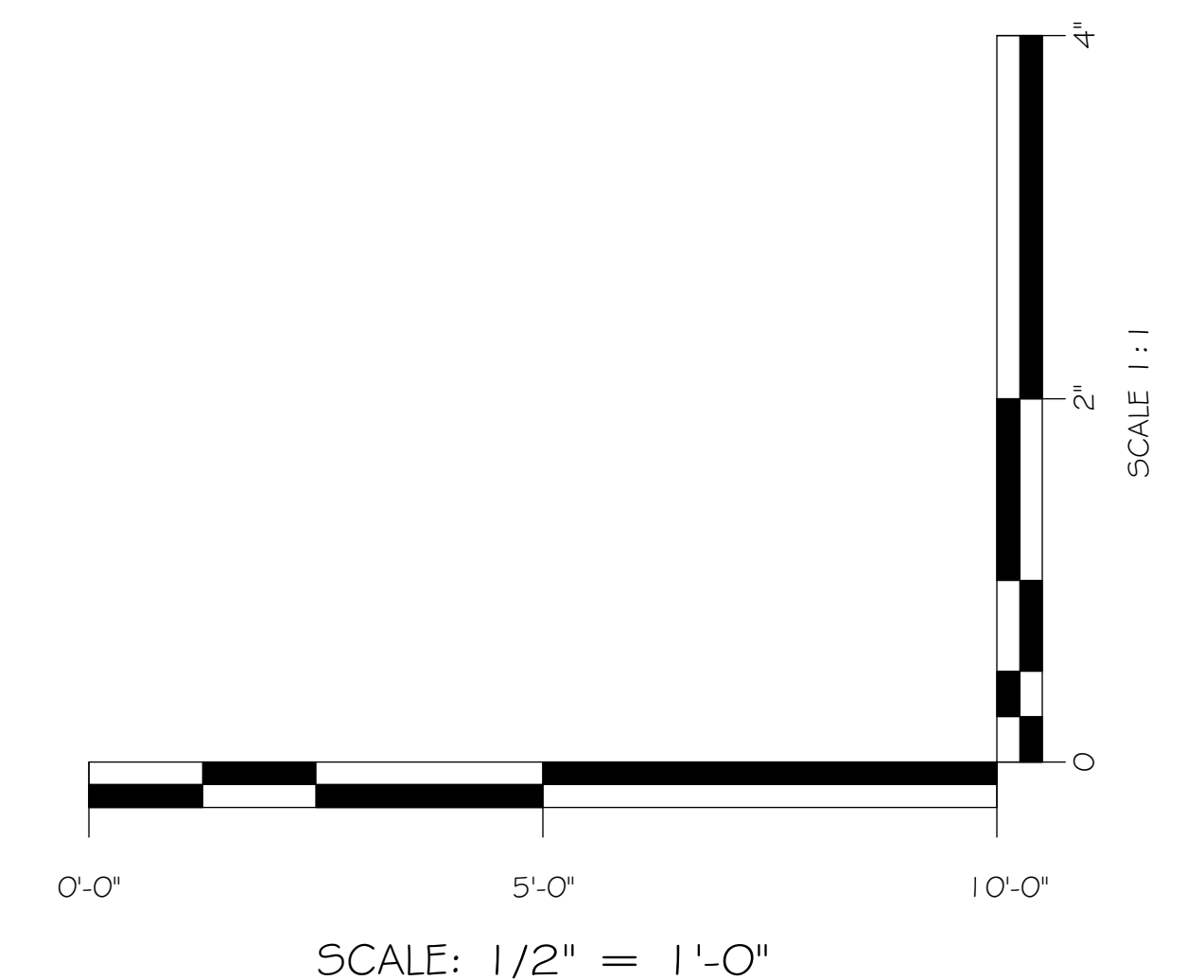

SCALE 1/2" = 1'-0"
DRAWN ON 05.08.2020

PLAN FOR UPPER LEVELS AND ELEVATIONS
NEW FREEDMAN THEATRE
DESIGNED BY CARL NOEL PROFESSOR JOHN COYNE

ROMEO & JULIET

PAGE

5

6

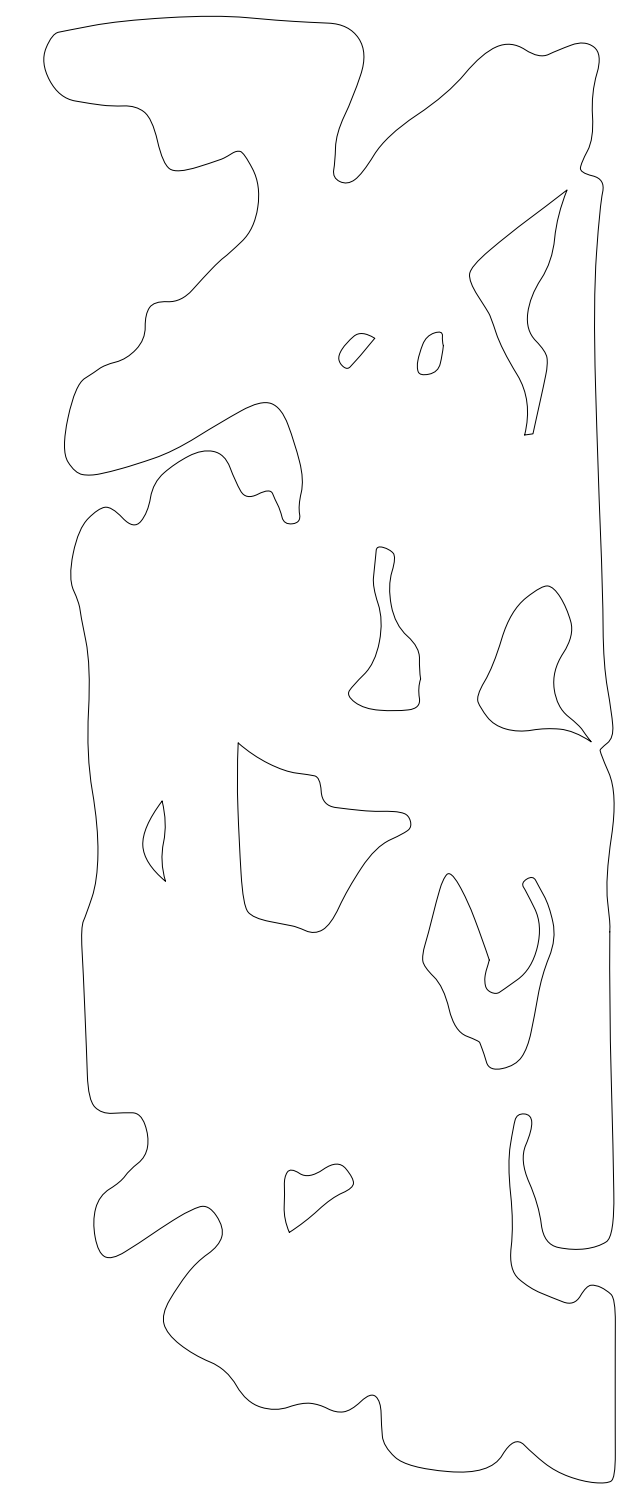

22 LINESET1
Scale: 1/2" = 1'-0"

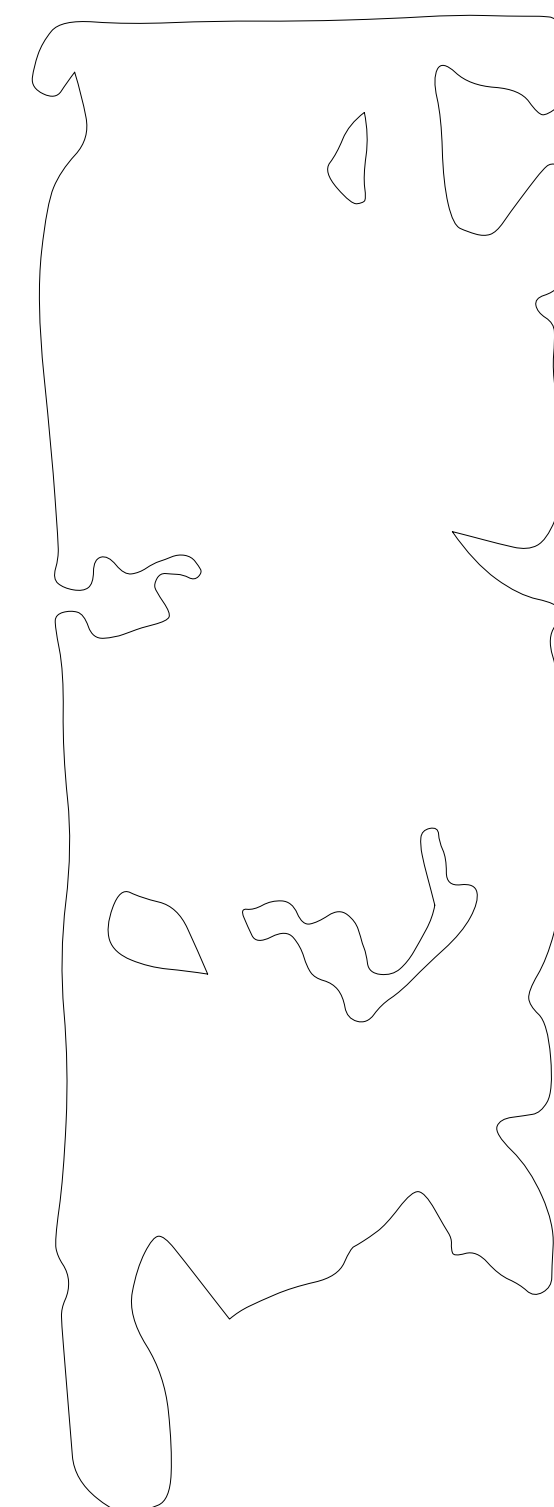

23 LINESET2
Scale: 1/2" = 1'-0"

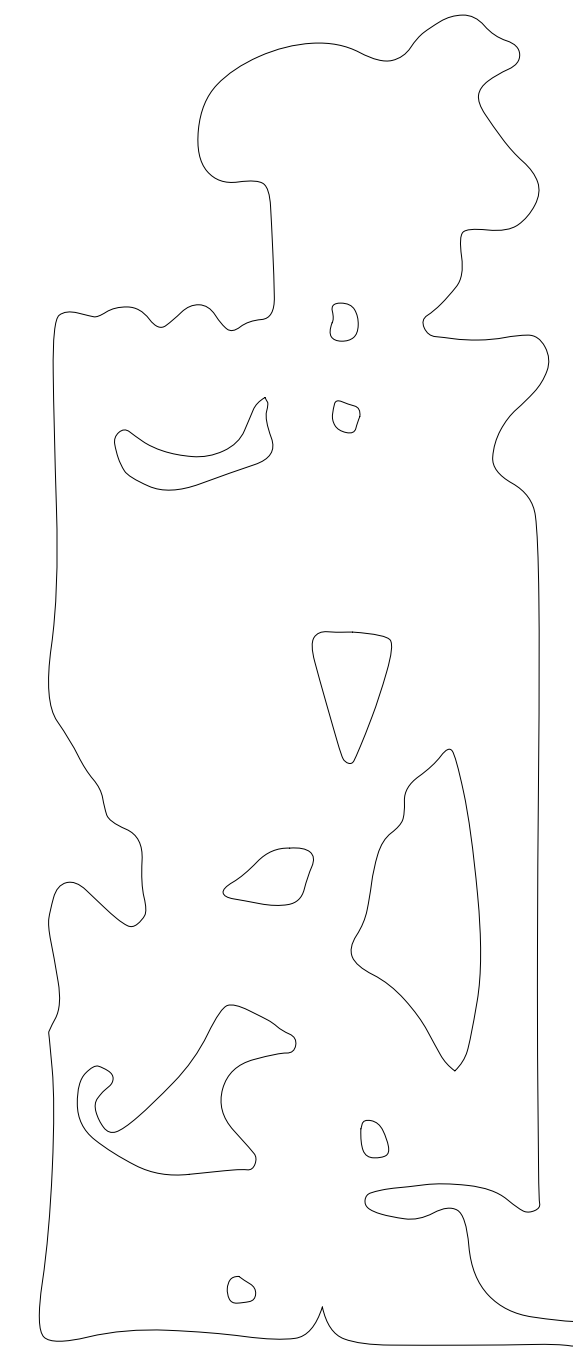

24 LINESET3
Scale: 1/2" = 1'-0"

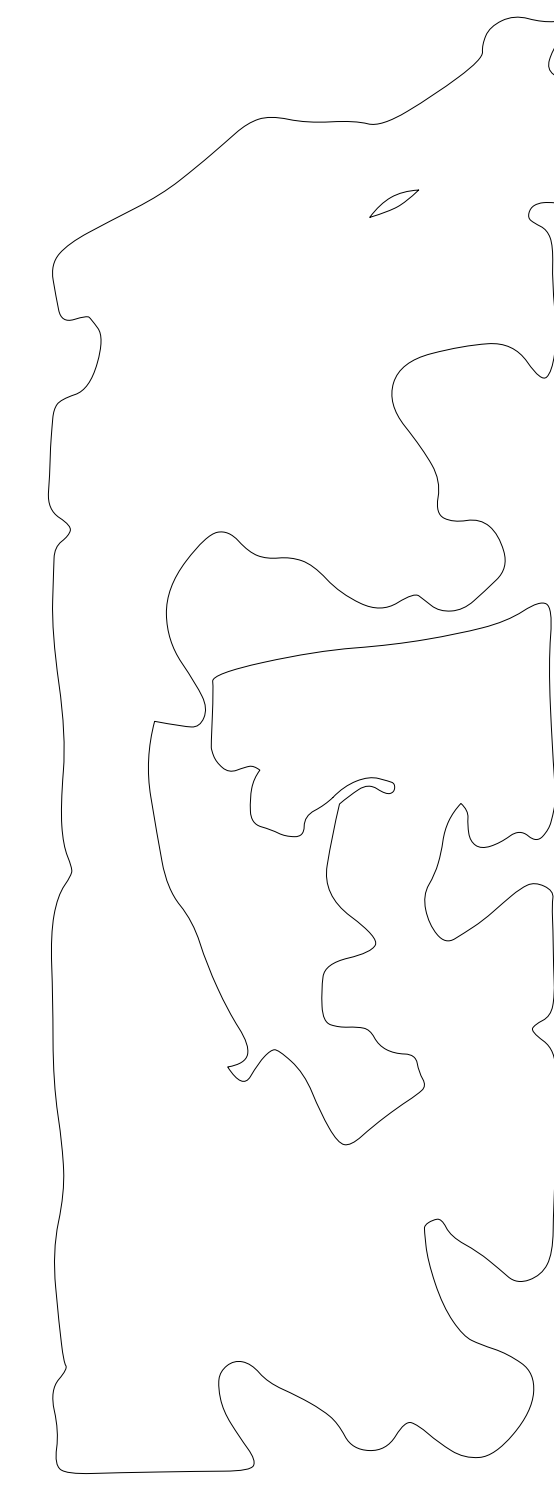
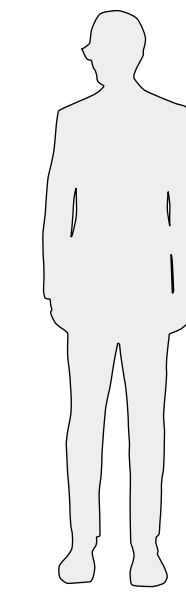

25 LINESET4
Scale: 1/2" = 1'-0"

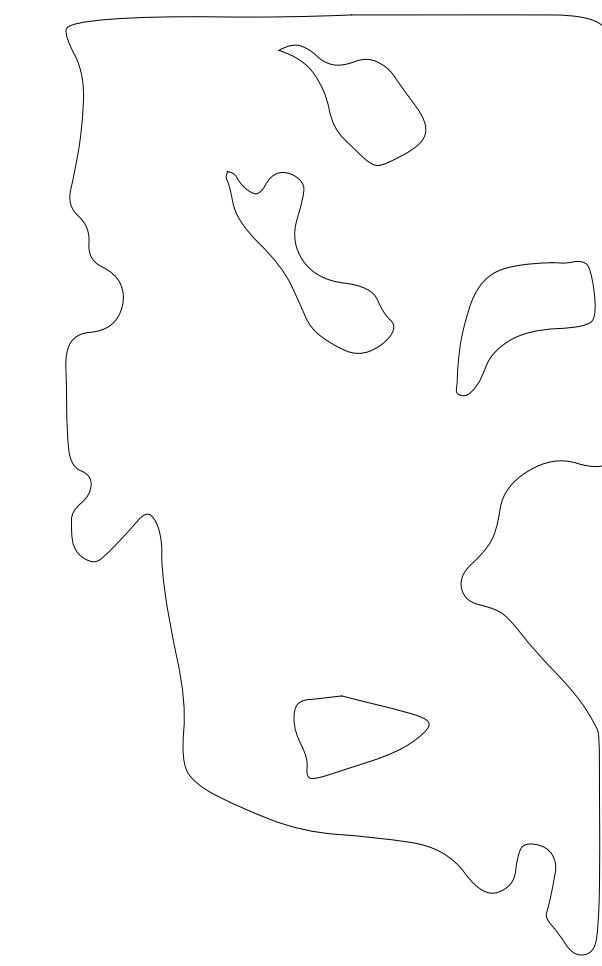

26 LINESET5
Scale: 1/2" = 1'-0"

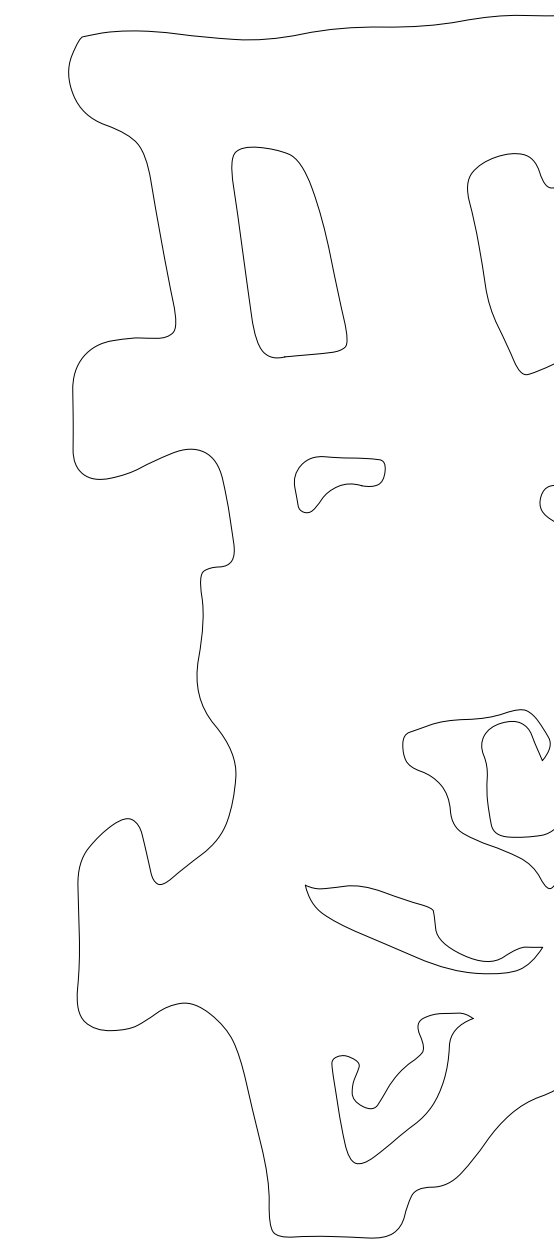

27 LINESET6
Scale: 1/2" = 1'-0"

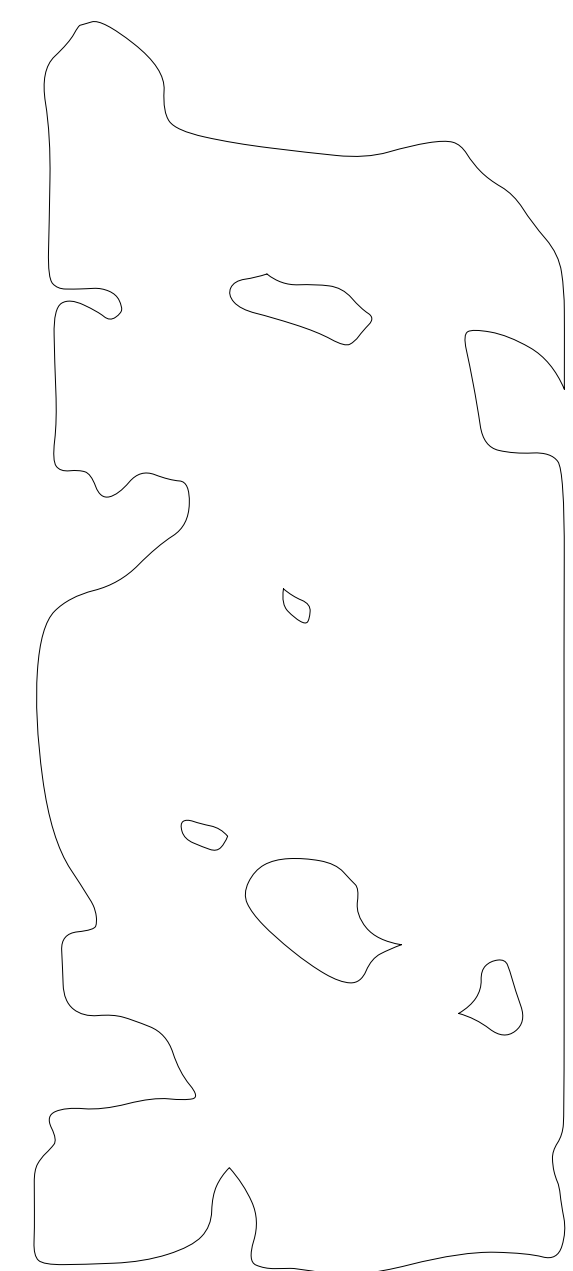

28 LINESET7
Scale: 1/2" = 1'-0"

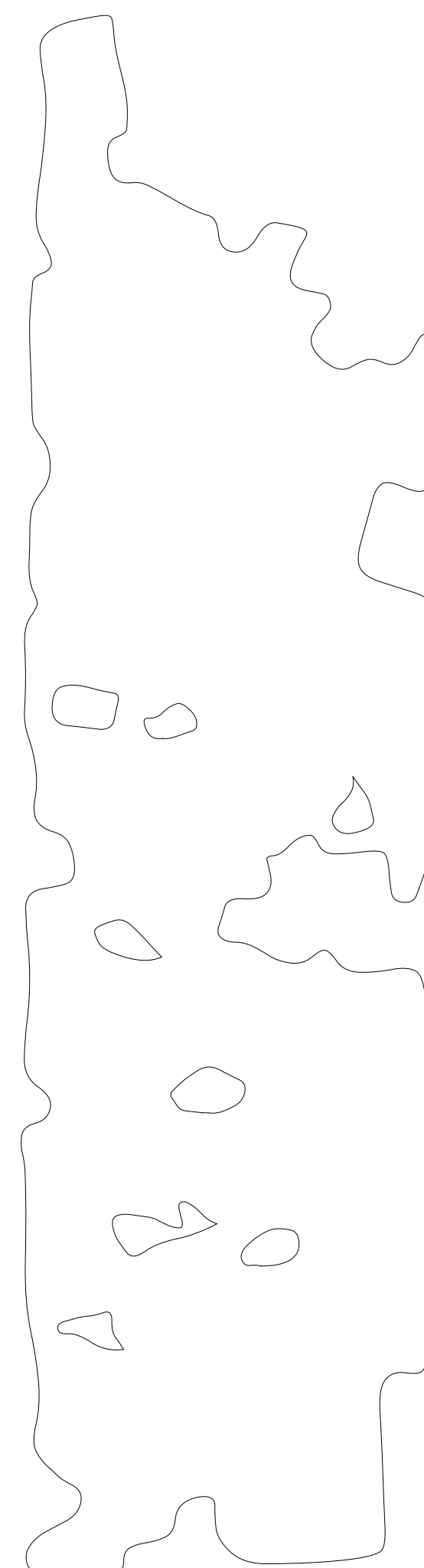

29 LINESET8
Scale: 1/2" = 1'-0"

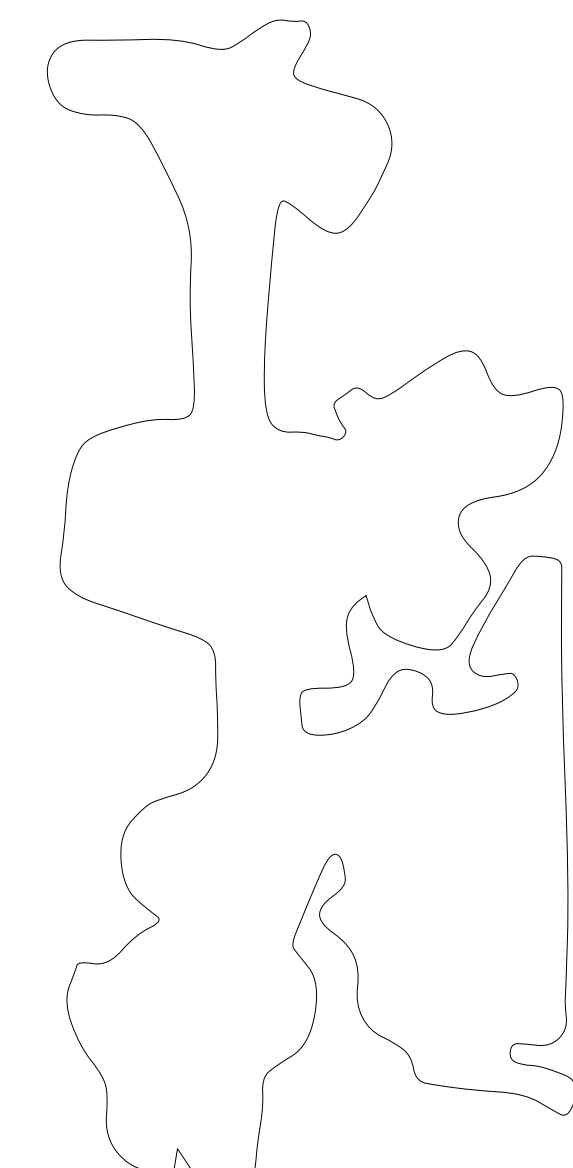

30 LINESET9
Scale: 1/2" = 1'-0"

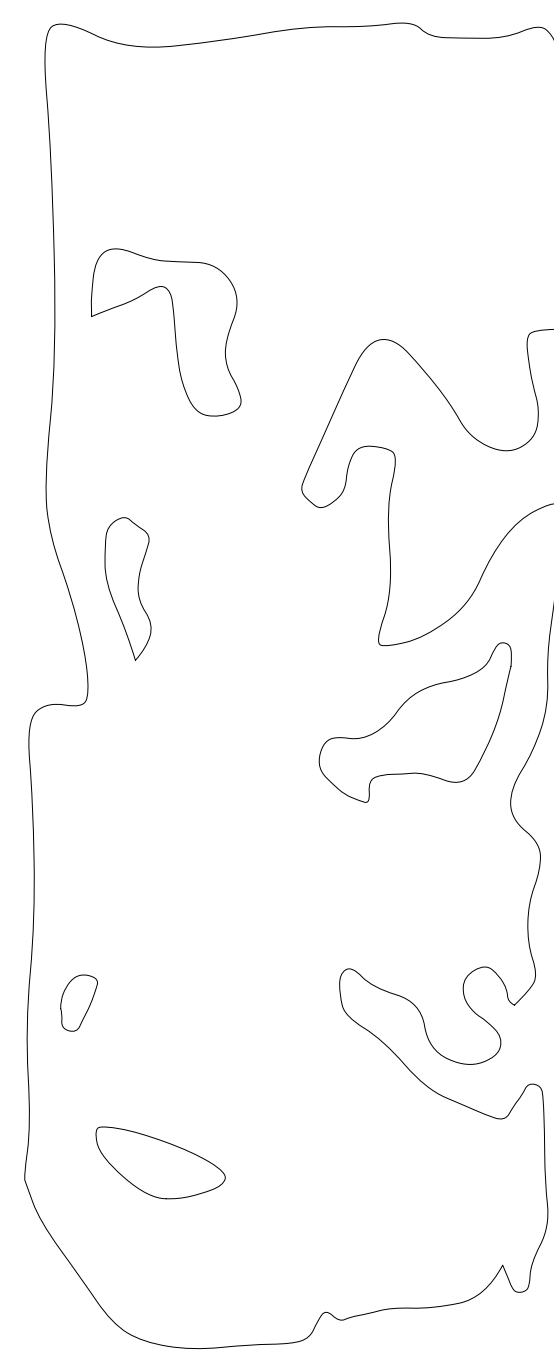
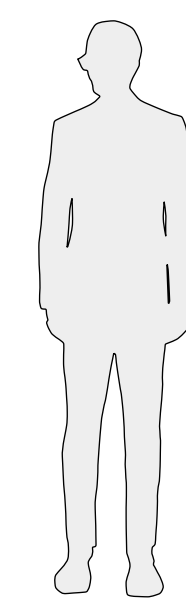

31 LINESET10
Scale: 1/2" = 1'-0"

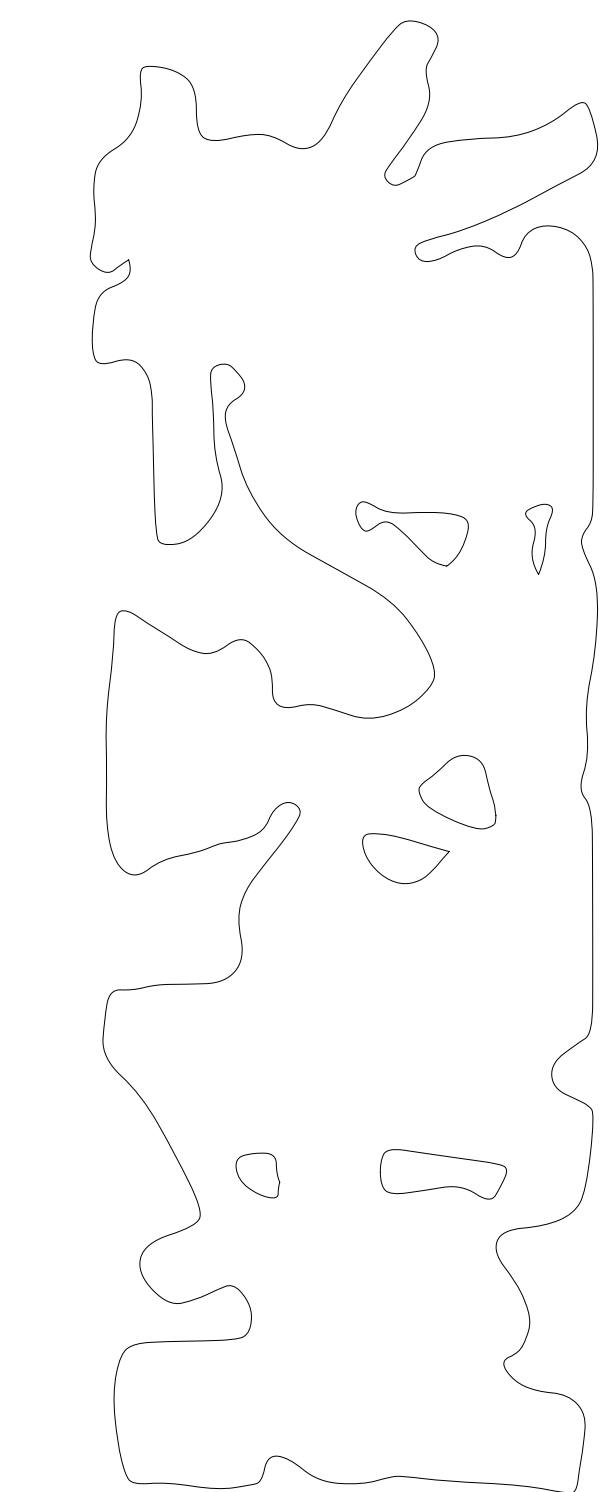

32 LINESET11
Scale: 1/2" = 1'-0"

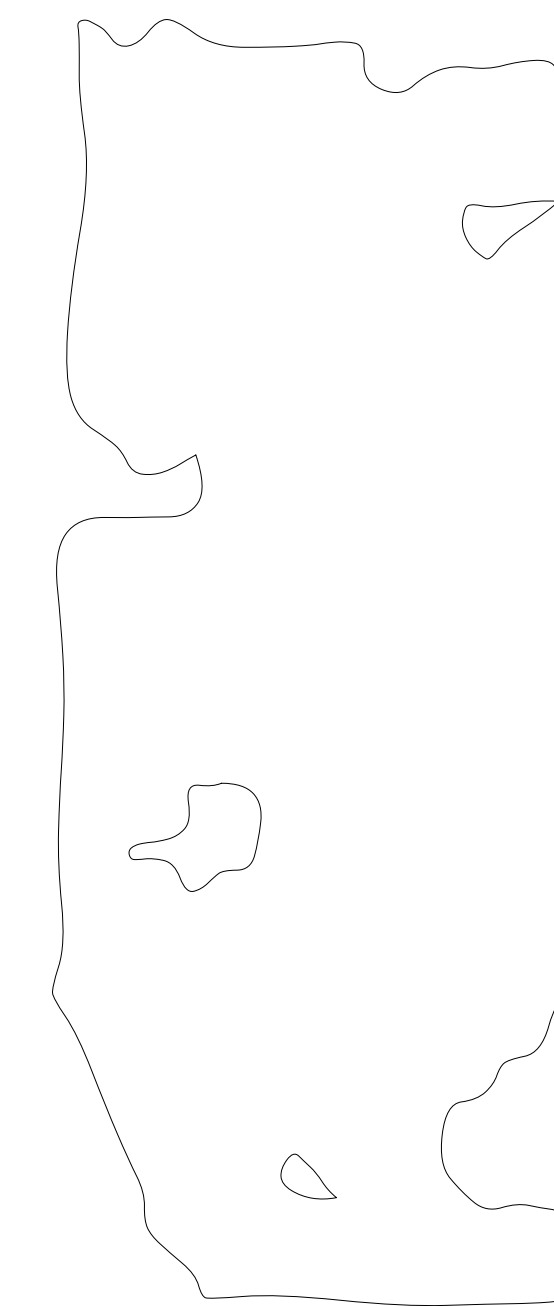

33 LINESET12
Scale: 1/2" = 1'-0"

-ALL LINESET FLATS ARE 1/2" ACRYLIC WITH A SCRIM OR SCREEN + GOUP TREATMENT ON THE DOWNSTAGE FACE.
 -THEY NEED TO BE SEMI-TRANSPARENT WHEN BACK-LIT AND OPAQUE WHEN FRONT-LIT.
 -HARDWARE CAN BE VISIBLE BUT WOULD LIKE TO DISCUSS
 -A BOLT AND PLATE WITH A D-RING AT THE BASE COULD WORK IF THE TECHNICAL DIRECTOR ADVISES THAT IT'S SAFE TO DO SO

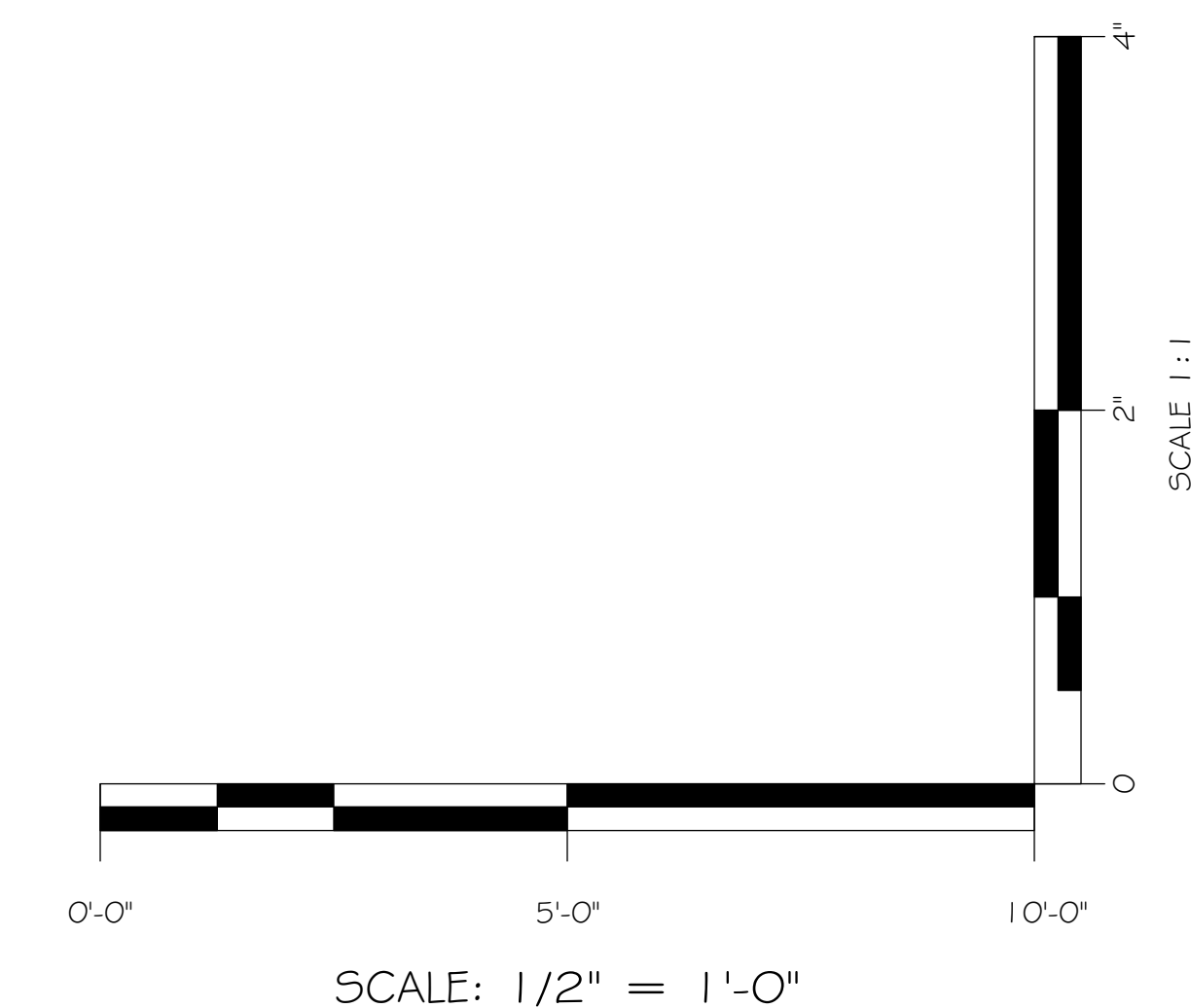

SCALE 1/2" = 1'-0"

ELEVATIONS FOR TRAVELLING FLATS

DRAWN ON 05.08.2020

NEW FREEDMAN THEATRE

DESIGNED BY CARI NOEL PROFESSOR JOHN COYNE

ROMEO & JULIET

PAGE

6

6